



環境研究と リモートセンシング技術

Remote Sensing for Environment Studies

東北大学東北アジア研究センター
佐藤 源之

sato@cneas.tohoku.ac.jp



内容

- Sensor and Satellite
- GIS (Geo Information System) and its application
- New information (Altimetry, Land Classification)

Observation of Iwate-Miyagi inner land earthquake observation by ALOS/PALSAR

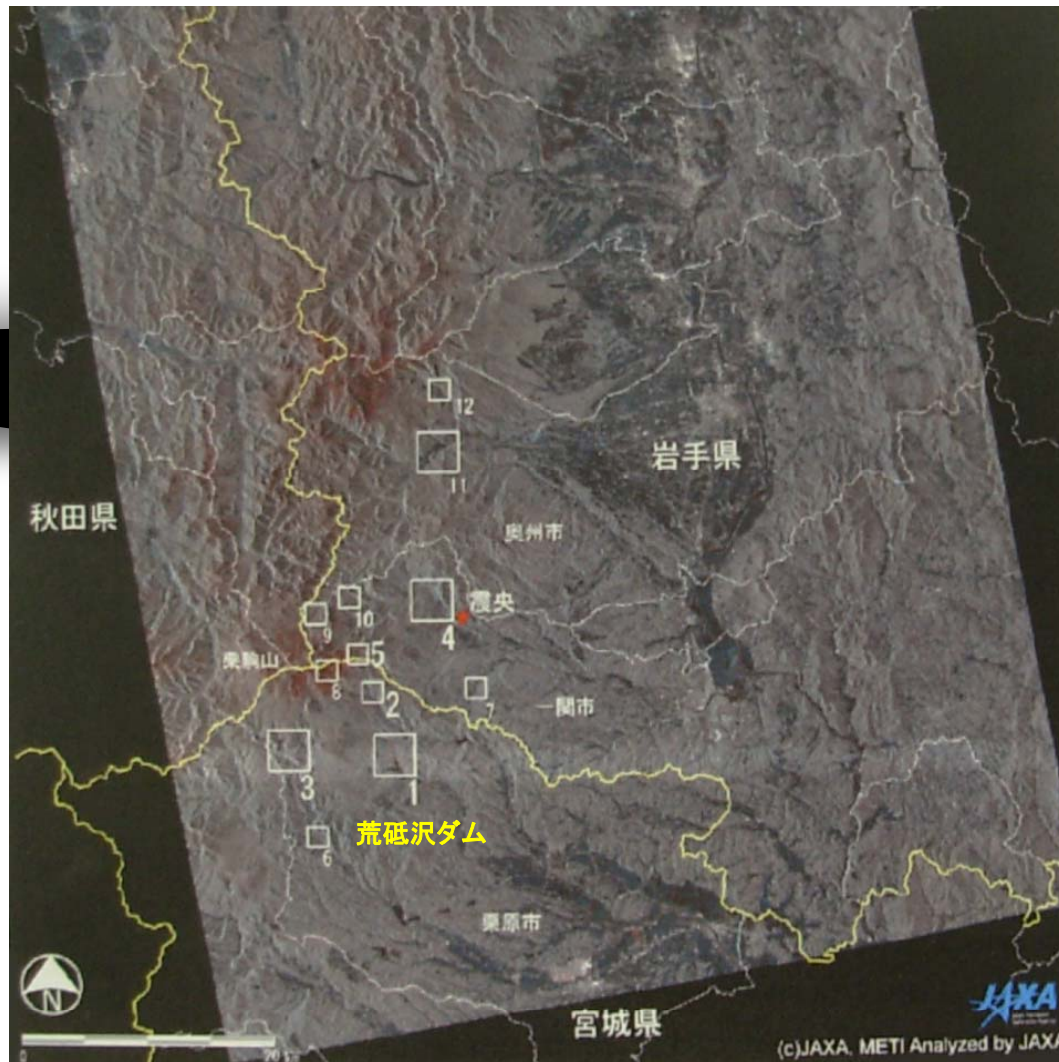

合成開口レーダの特徴

昼夜天候に関係なくデータ
取得可能

使用画像

2008年3月23日(緑、青)

2008年6月23日(赤)

赤: 電波強度明るくなる

青: 電波強度暗くなる

地震前後のカラー合成画像

1、荒戸沢ダム

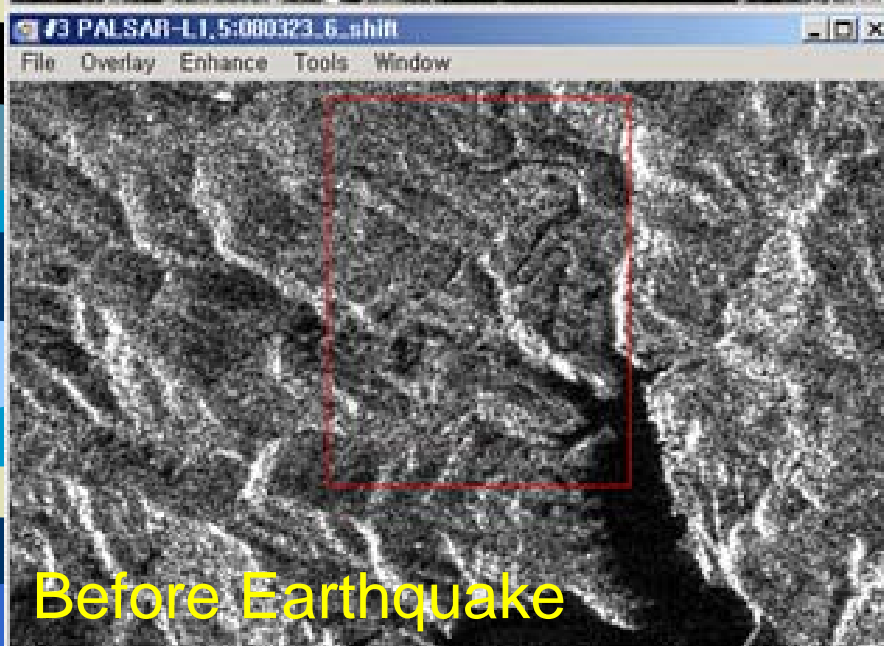
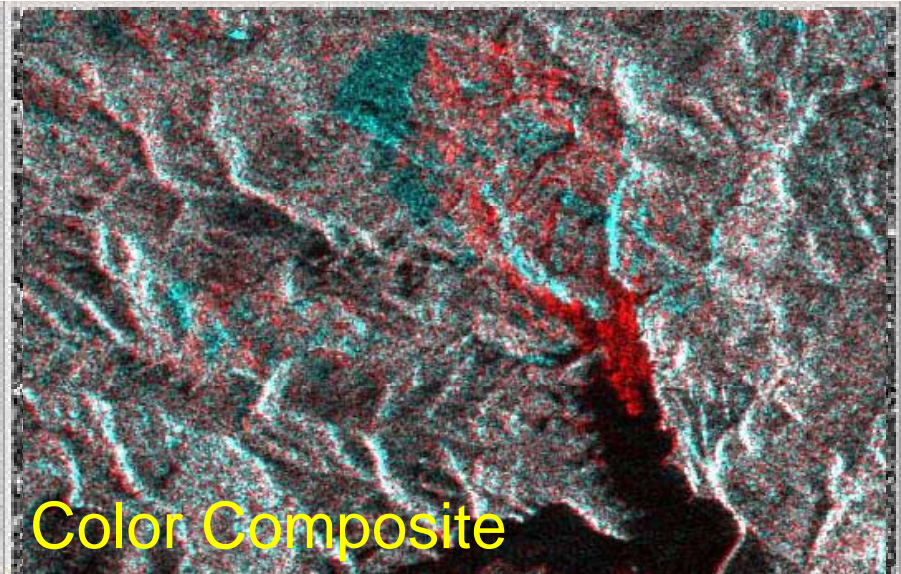
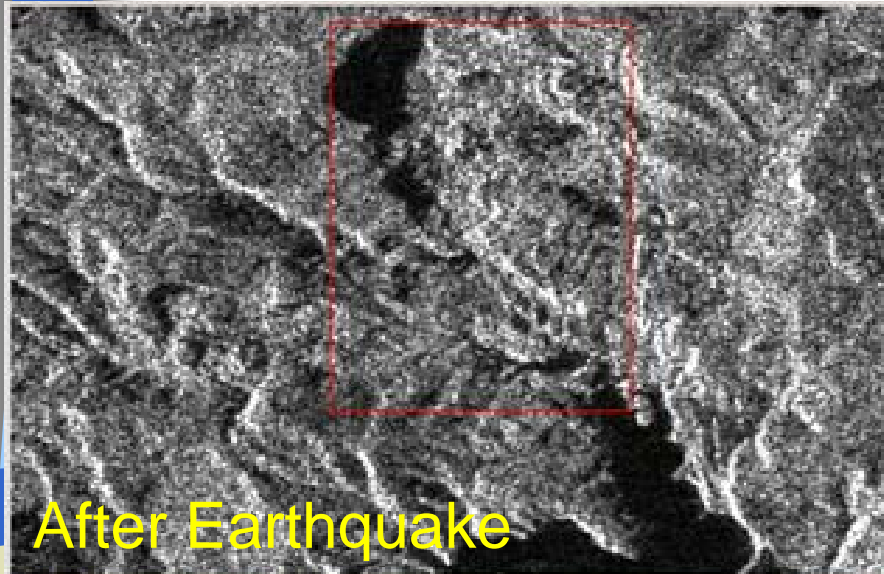

Komano-yu

ドゾウ沢

Optics

SAR

2 [km]

駒の湯温泉

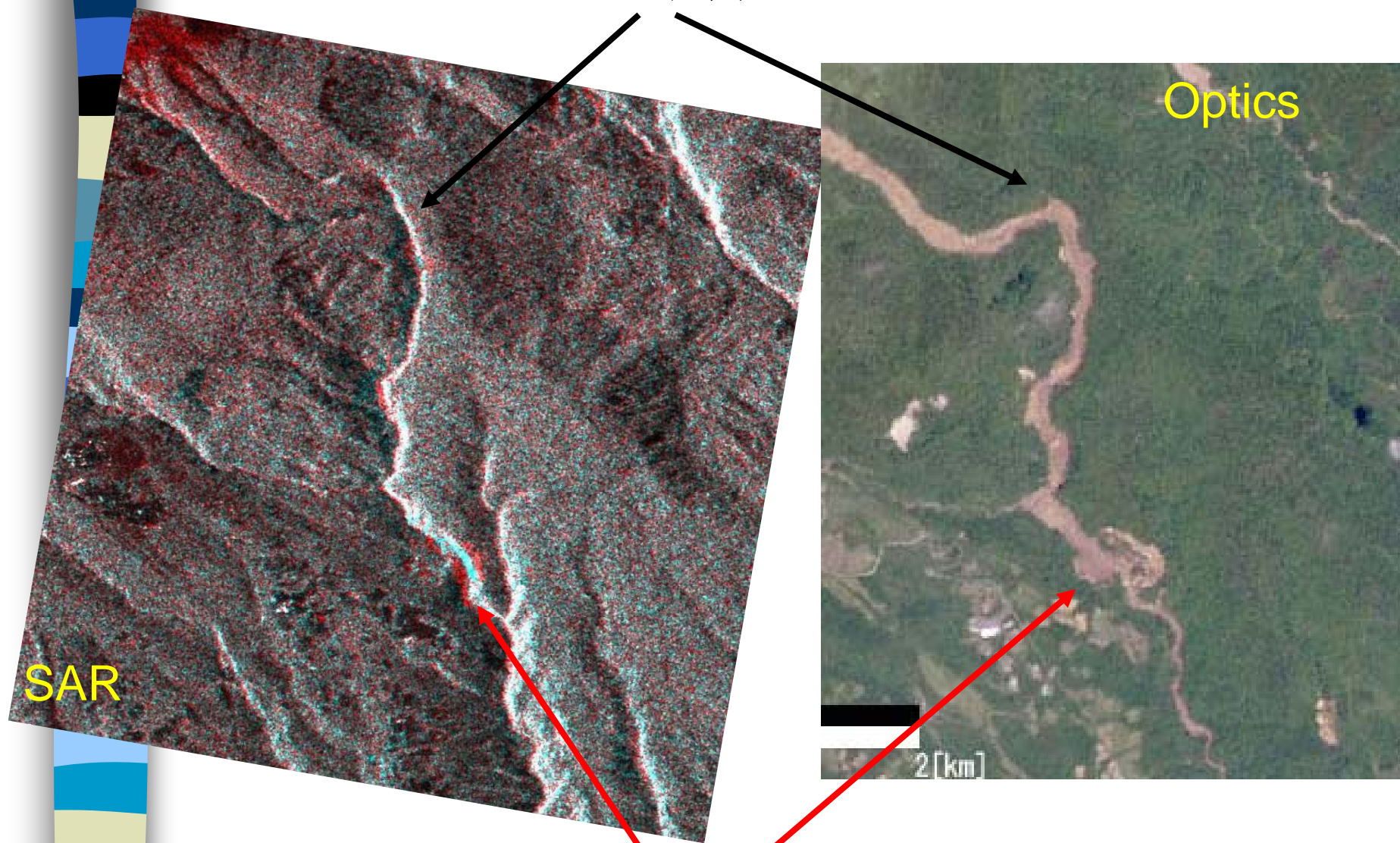

レーダポーラリメトリを用いた土砂災害域の検出

岩手・宮城内陸地震 駒ノ湯周辺(2008年6月14日)

土砂災害域が1回散乱(青色)で良く検出できる

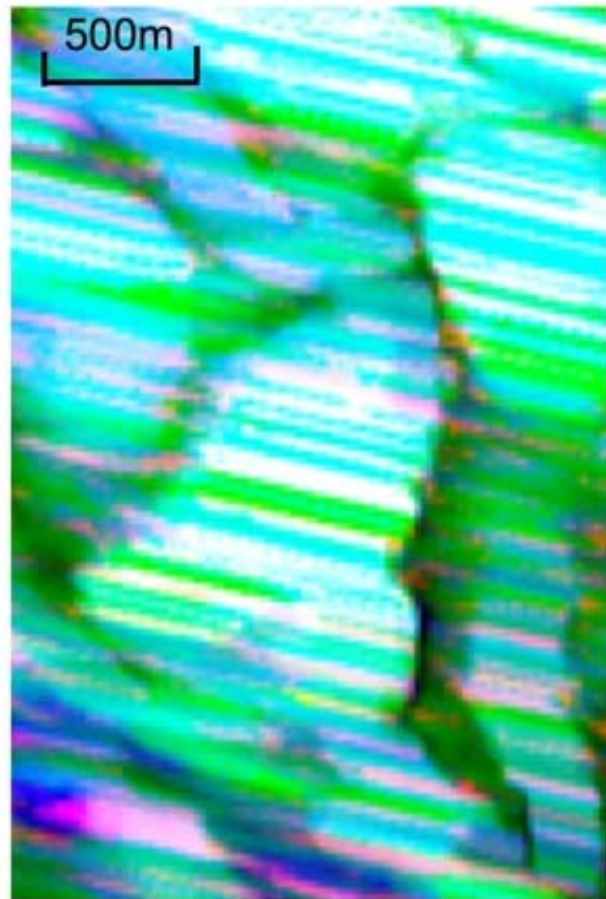

災害前

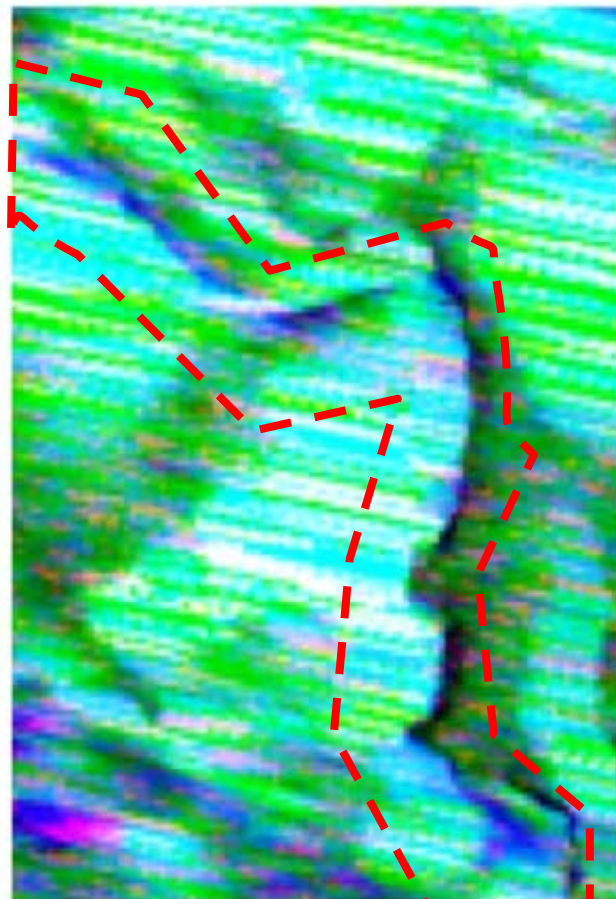

災害後



災害後(光学センサ)

ALOS/PALSAR レーダポーラリメ トリによる大規模土 砂災害域の検知

国土地理院
岩手宮城内陸地震災害状況図を使用

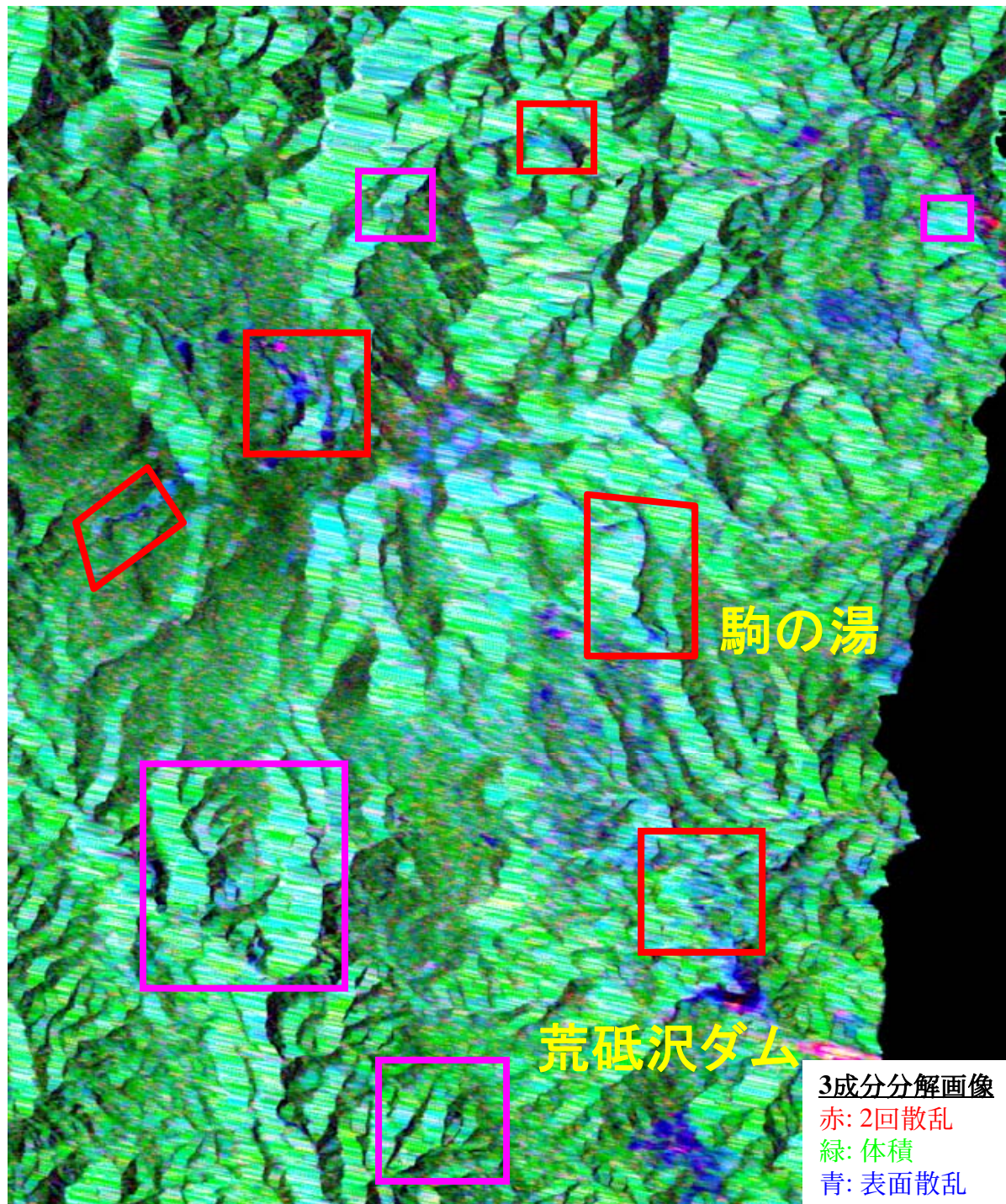

SAR-Interferometry

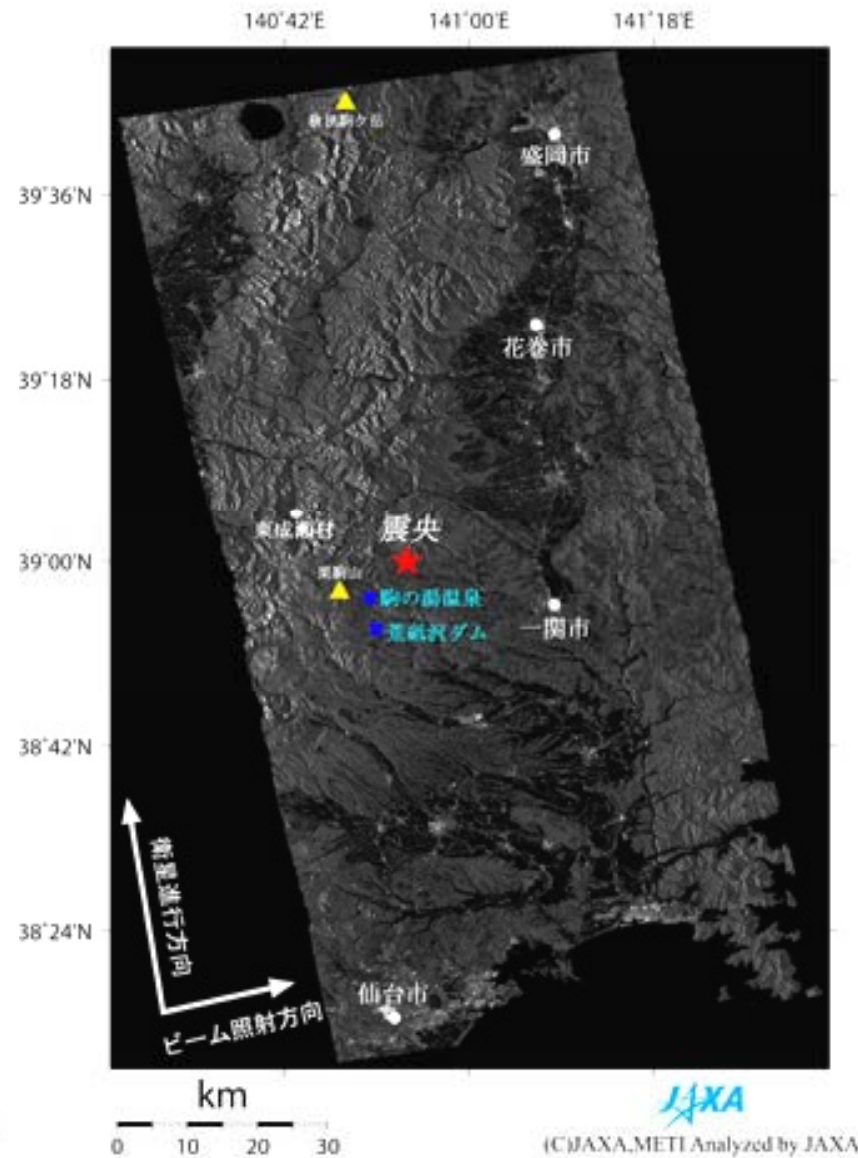
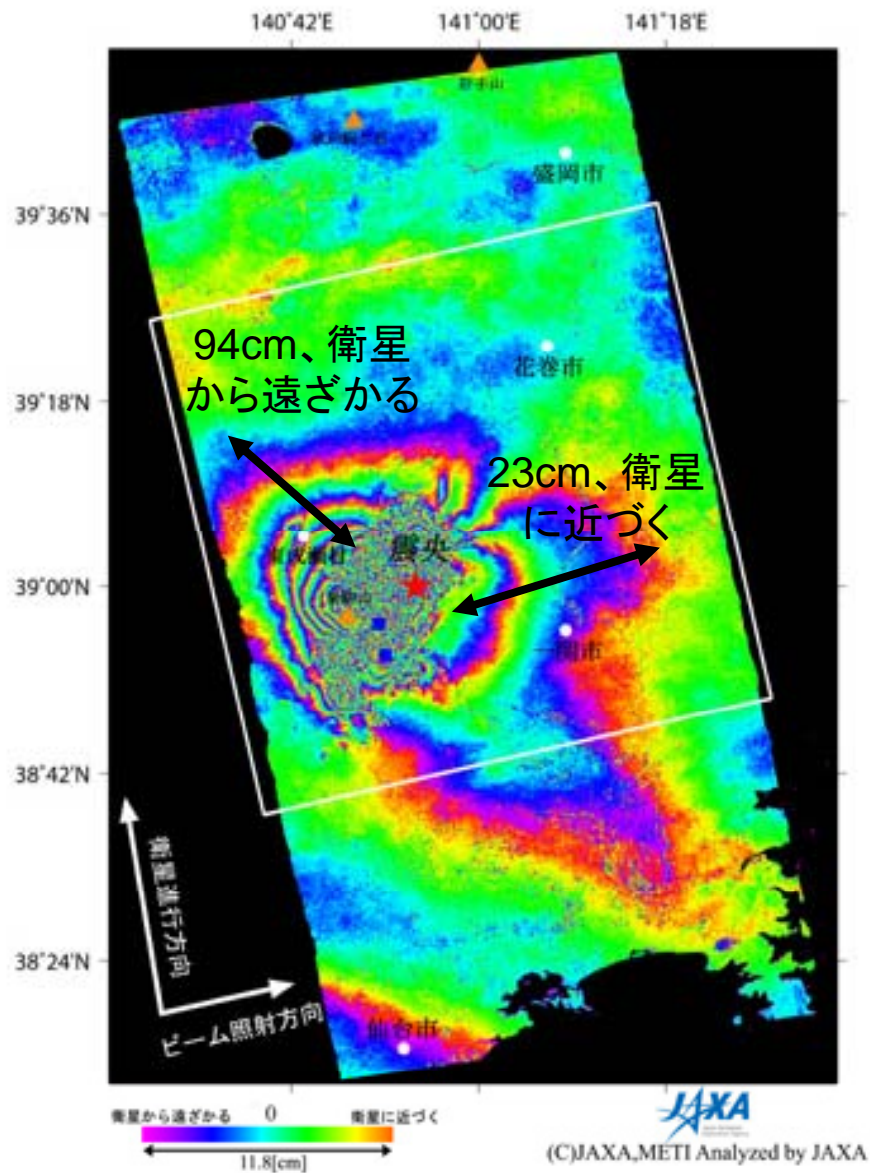

Radar platform





Earth Observation Satellite

- 陸域観測技術衛星 (ALOS)
- 環境観測技術衛星「みどりII」 (ADEOS-II)
- EOS-PM1衛星 (AQUA)
- 熱帯降雨観測衛星 (TRMM)
- 地球観測プラットフォーム技術衛星「みどり」 (ADEOS)
- 地球資源衛星1号「ふよう1号」 (JERS-1)
- 海洋観測衛星1号／1号-b「もも1号／1号-b」 (MOS-1/1b)
- ランドサット衛星 (LANDSAT)
- スポット衛星 (SPOT)
- ヨーロッパリモートセンシング衛星 (ERS)



Environmental Survey

- Understanding the current status: global-time varying
- Future estimation of Environment: Quantitative measurement
- Financial effect: Carbon dioxide-Kyoto protocol

Satellite remote sensing : Global observation

- Land use
- Geology
- River
- Sand Dur
- Road
- Vegetatio
- Iceberg



TRMM/PRによる地表面観測

入射角依存性を考慮した合成カラー画像

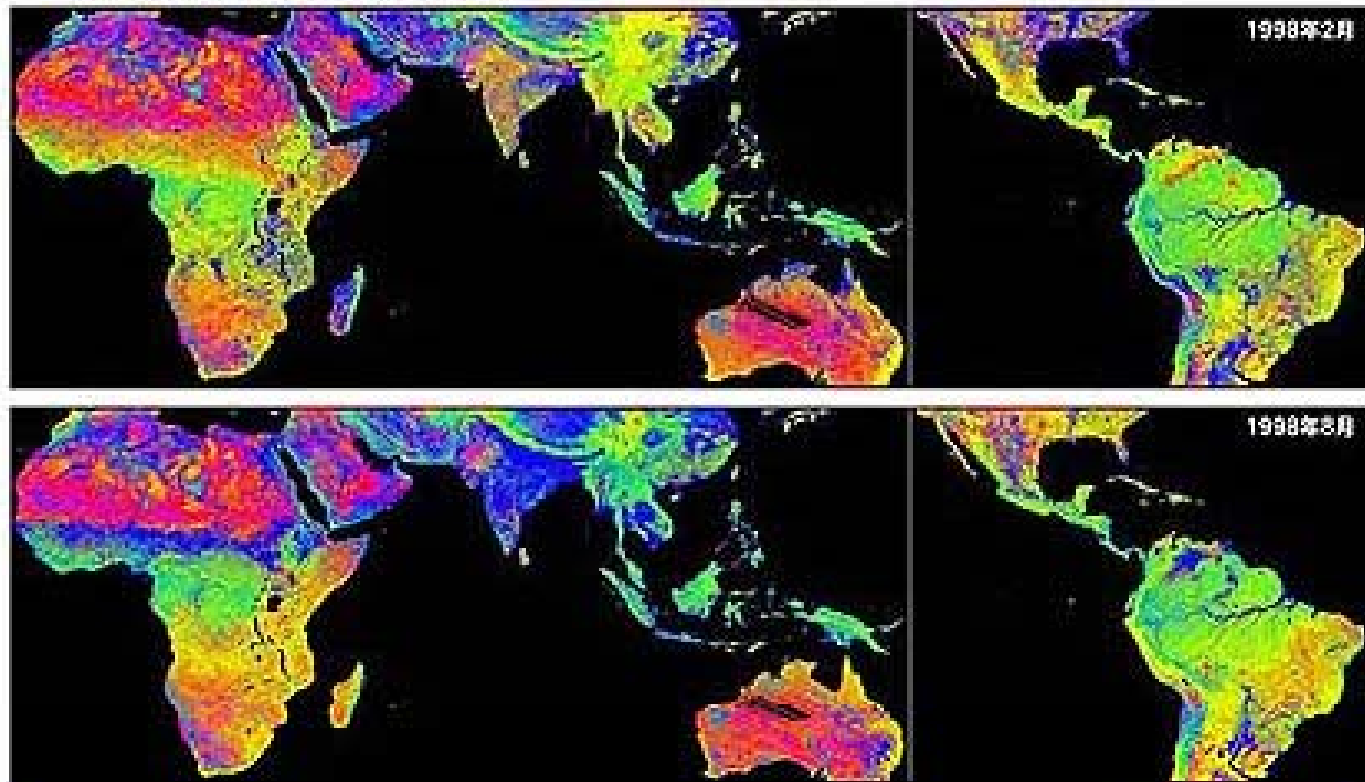

■: 森林密度に対応 (0-8度)
 ■: 水田・土壌水分に対応 (0-10度)
 ■: 裸地・荒地に対応 (14-18度)

Vegetation: Classification

Agriculture

Crop Type

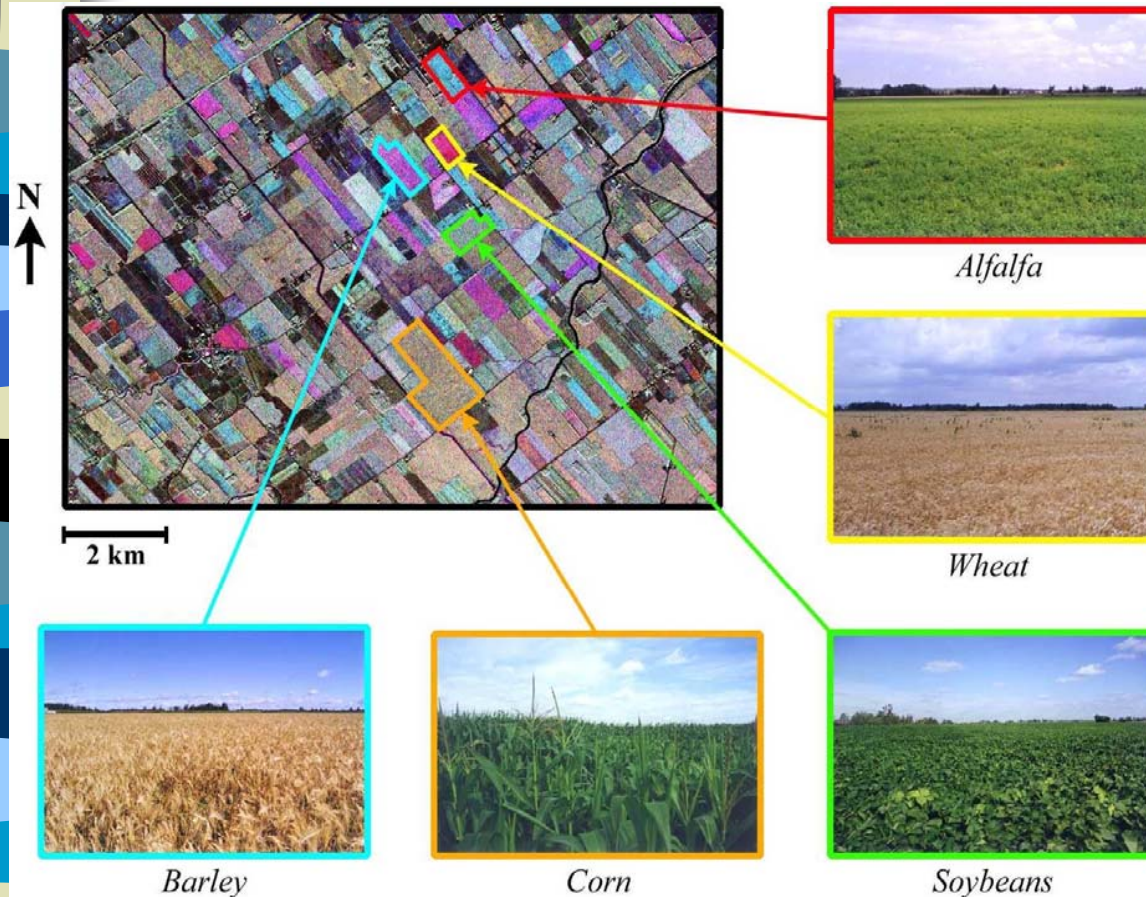

Airborne CV-580 C-Band SAR
South of Ottawa, 1998 July 9
Linear Polarization Composite

R = HH G = HV B = VV

The availability of multiple polarizations will greatly improve the potential for crop type mapping

Ice



図2 RADARSAT広観測幅モードによる北海道北東部周辺の観測例
(1998年3月2日 ©CSA)



図3 PI-SAR Lバンドによる海氷の多偏波観測例 (1999年2月23日)



Invisible object

- Physical measurement
 - Ground Water
 - Mineralogy
 - Time-variance
- Quantitative measurement
 - Biomass
 - precipitation
 - Agricultural products
 - DEM

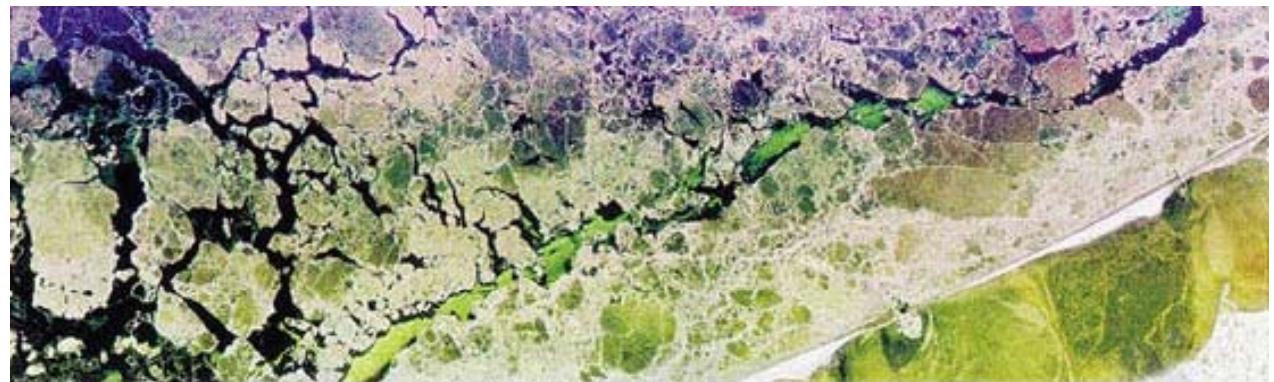
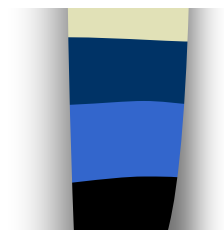
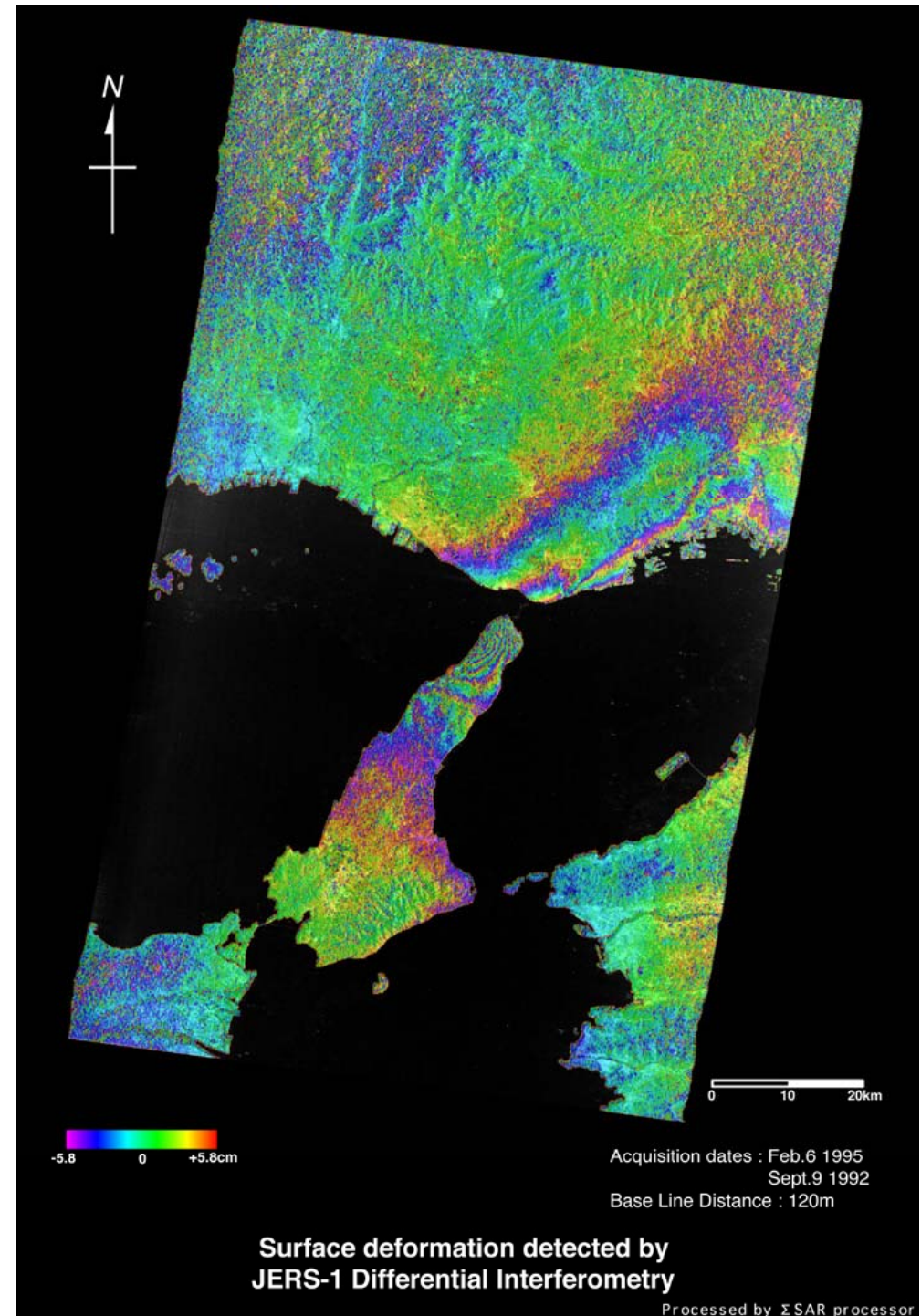



Iwate-san volcano

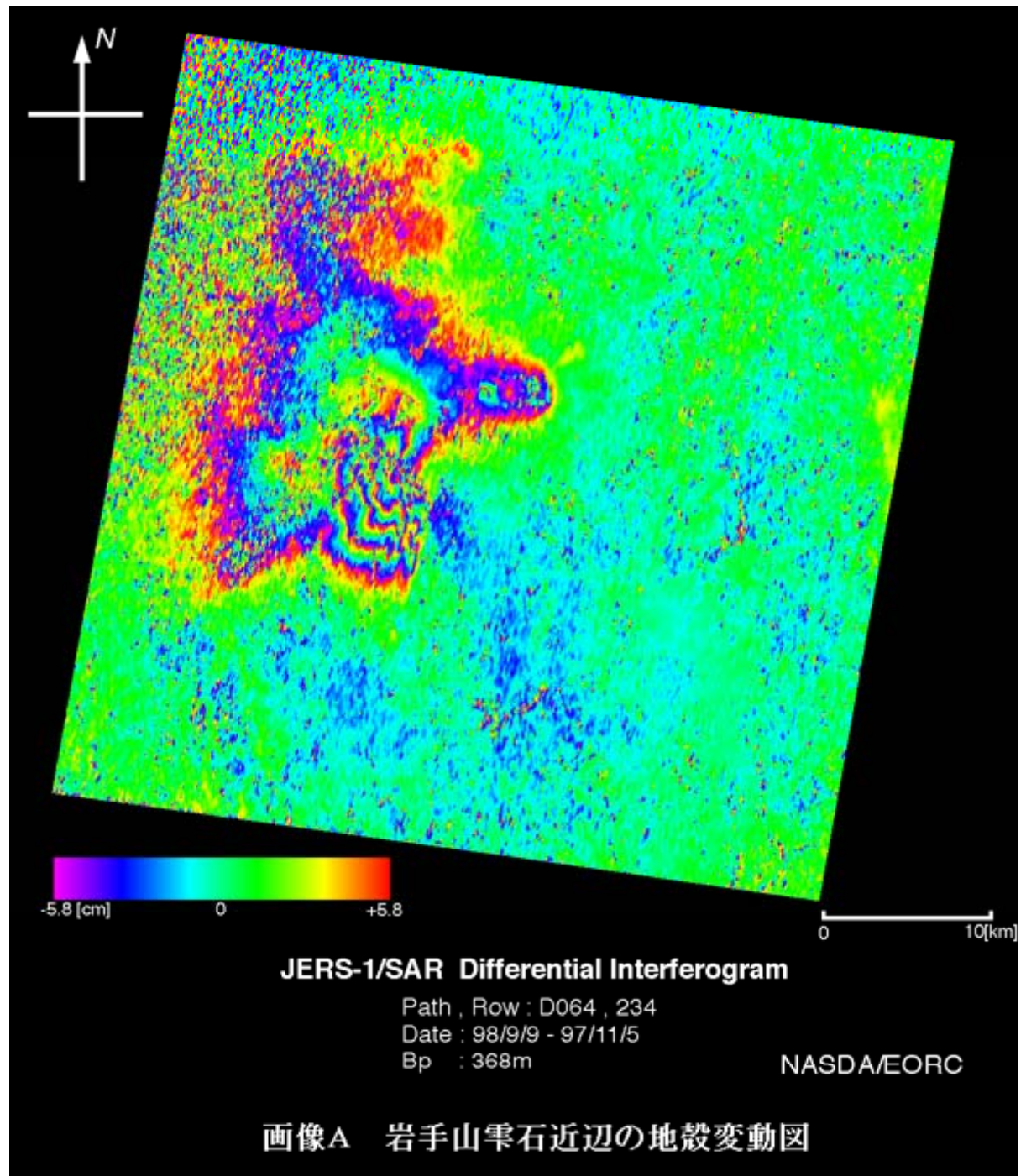

Biomass



画像3 JERS-1のSARを用いたアフリカ中央部のモザイク画像。森林からのレーダ反射強度は、水面や伐採地や裸地より明るく見える。

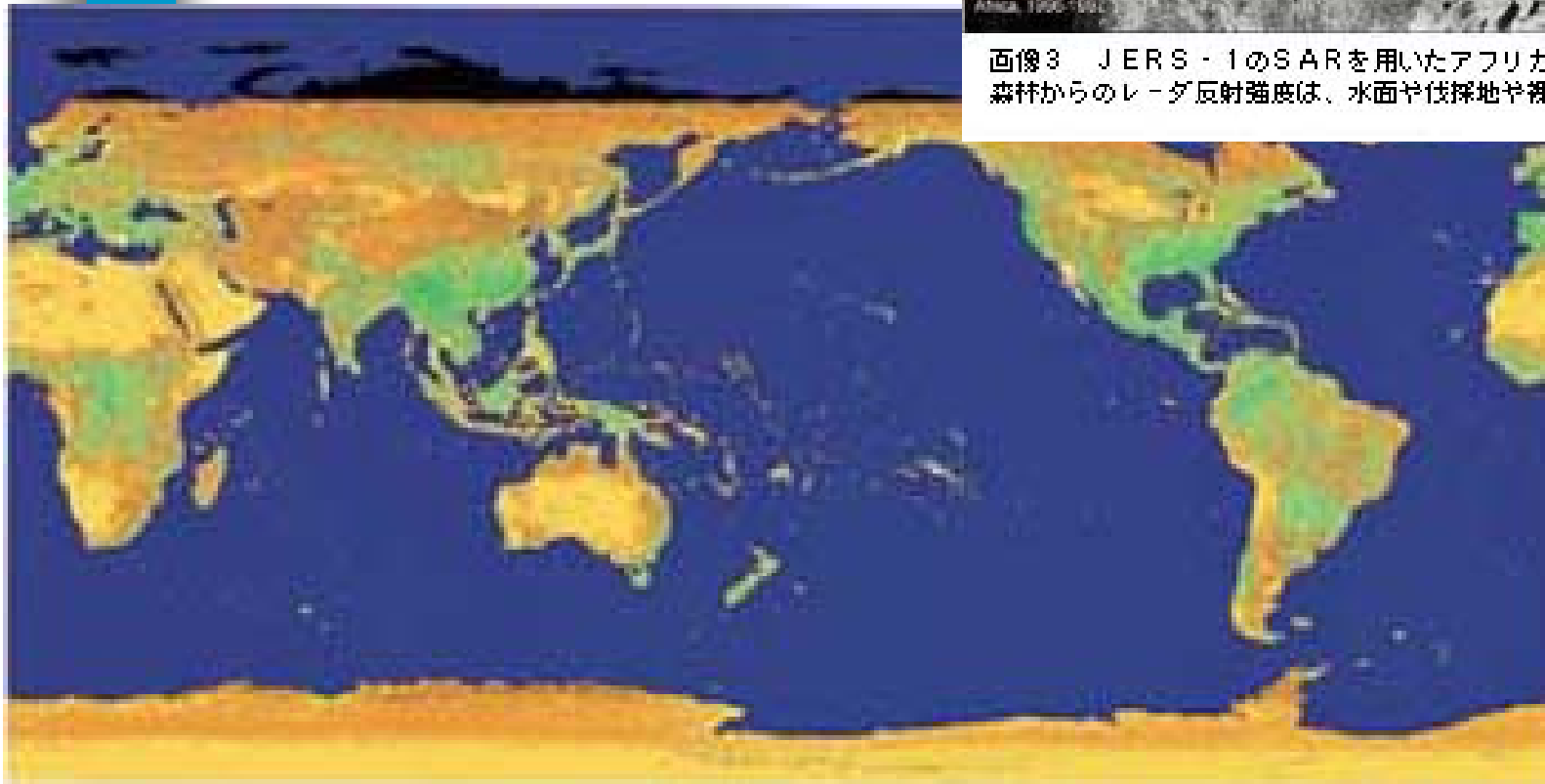

画像2 画像1から作成したグローバルな規格化植生指標 (NDVI) 画像。南米アマゾン河流域は雲の影響が取りきれず、実際より指標が小さめになっている。

Tokyo bay

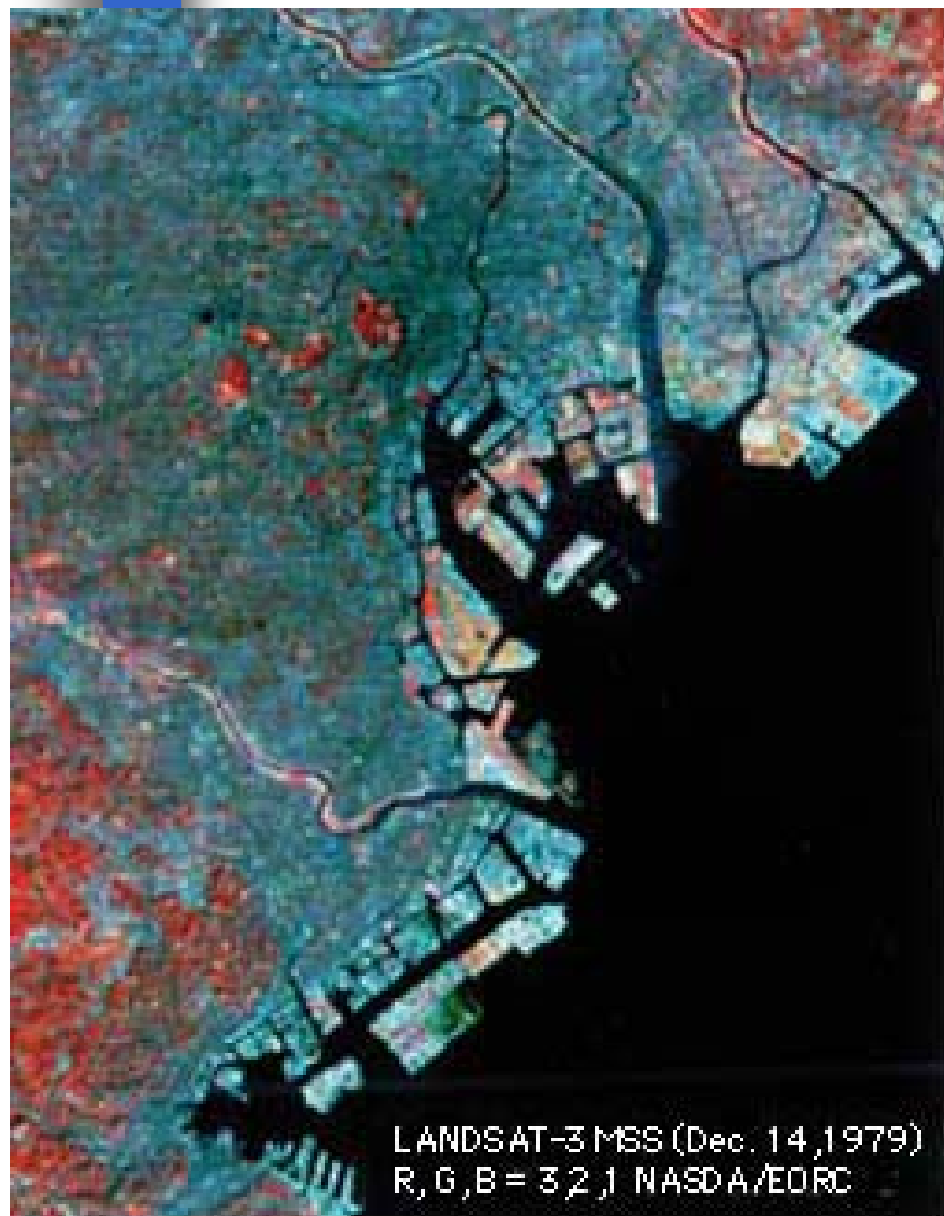

Takuramacan desert, Talim river

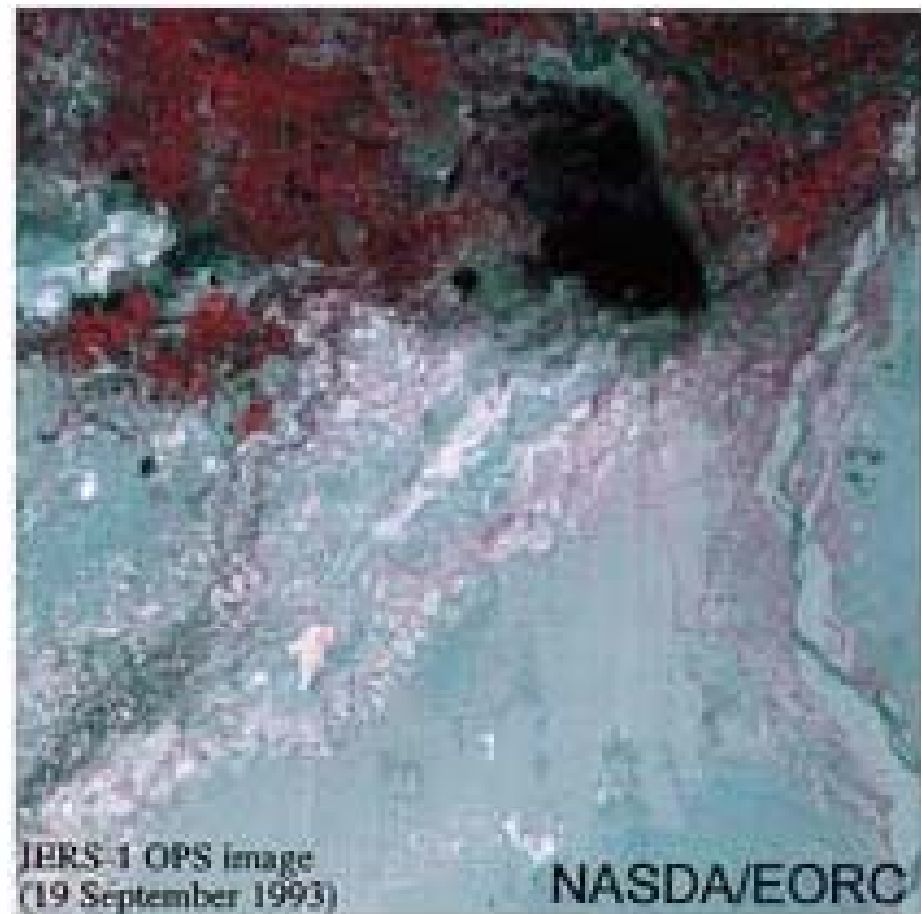
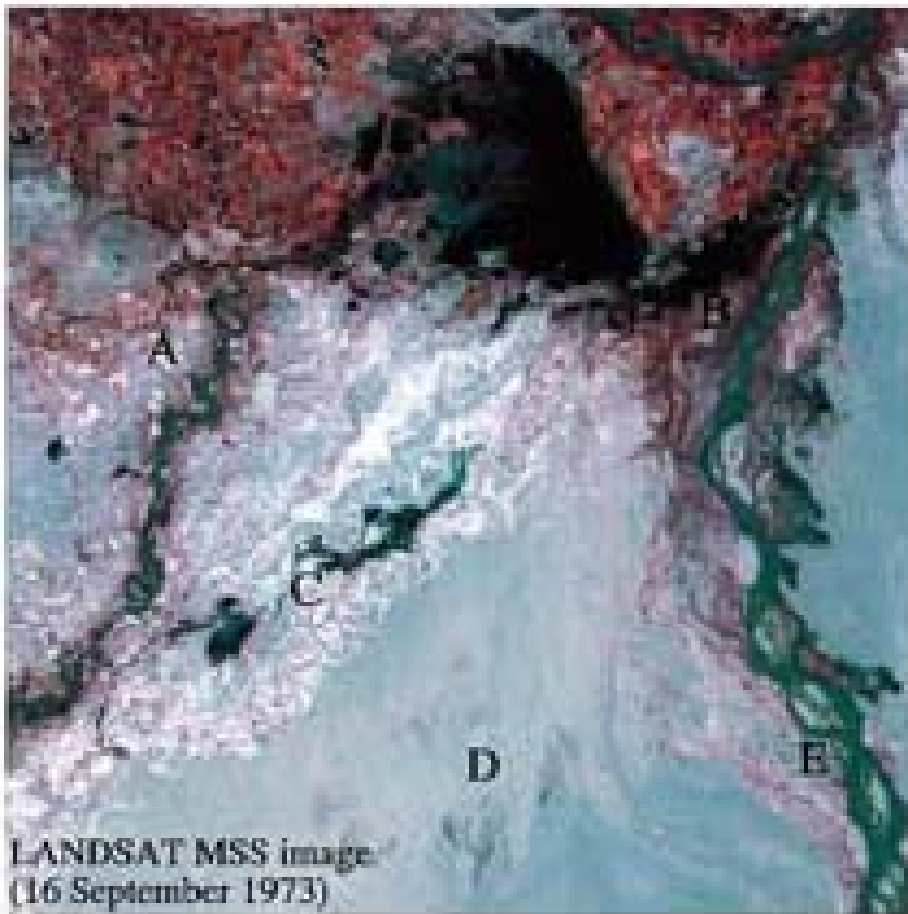



Sensor

Optical

Multi-spectral

Passive

No transmitter

- Radiometer (MW)

Microwave (MW)

Cloud independent

Active

Weather and time independent

- SAR (MW)
- Scatterometer (MW)

Passive sensor

Reflection of sun light

Electromagnetic wave emitting from objects

- Infrared
- Visible optics
- Microwave

(All of them are electromagnetic wave)

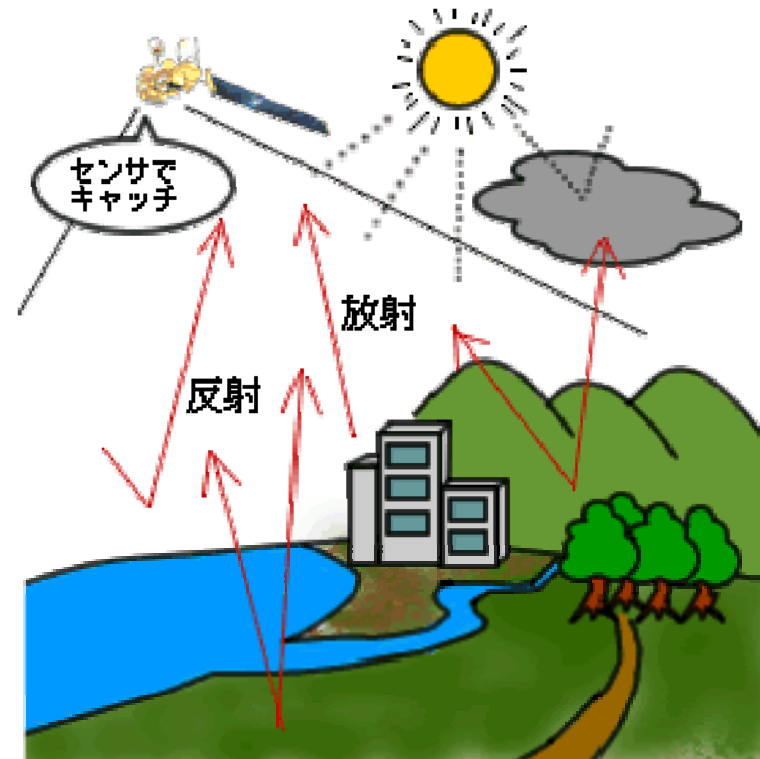
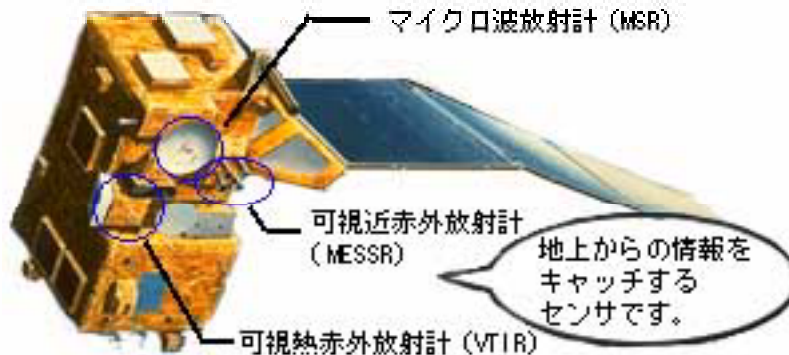

海洋観測衛星1号「もも1号」(MOS-1)

Reflection and Emission of Electromagnetic wave from Objects

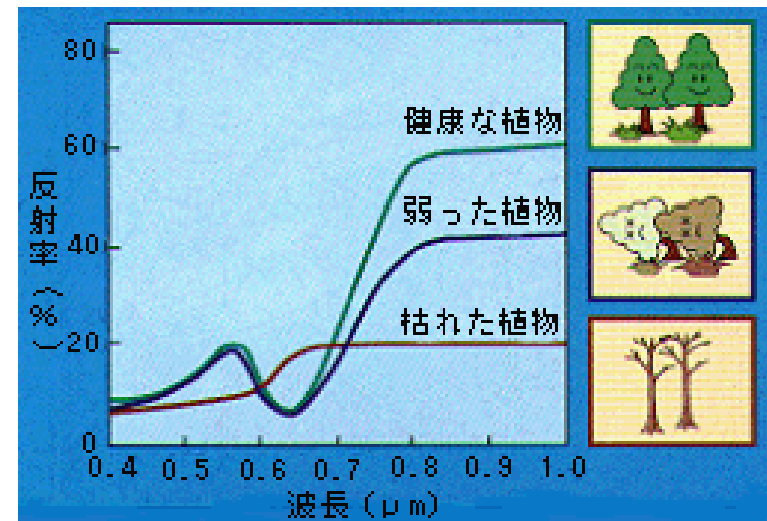
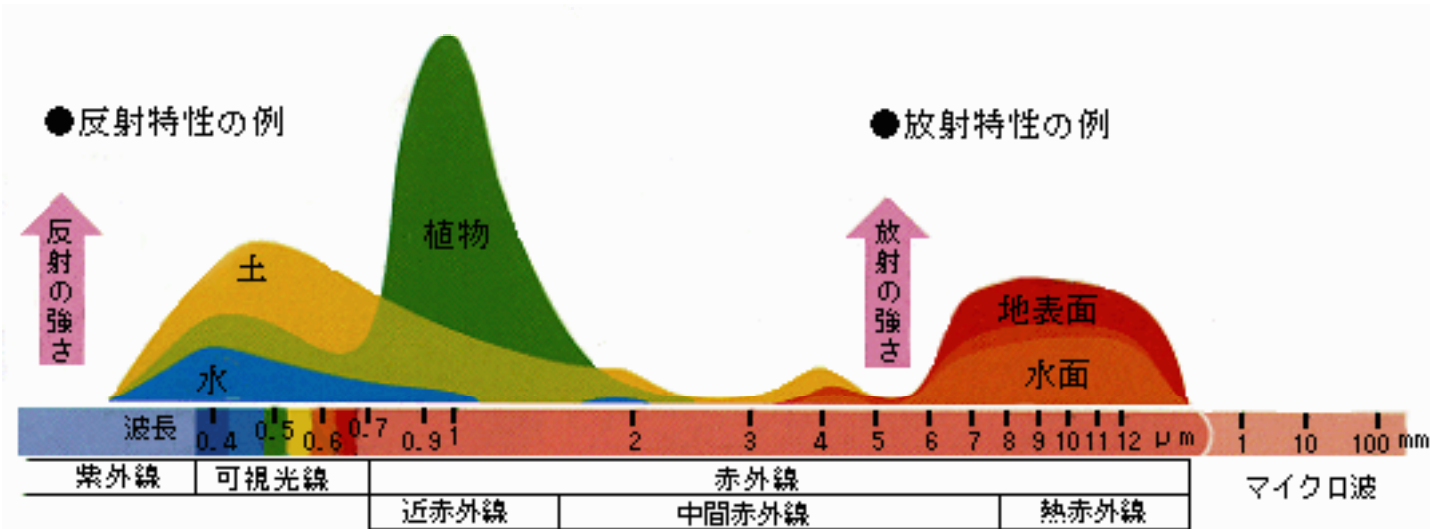



Active sensor

- Microwave radar (RADAR: Radio detection and ranging)
- SAR :Synthetic Aperture Radar(Imaging radar)
- Scatterometer (Non- imaging, RCS: Radar cross section measurement)
- Laser radar (LIDAR: Light Detection and Ranging)

Synthetic Aperture Radar (SAR)

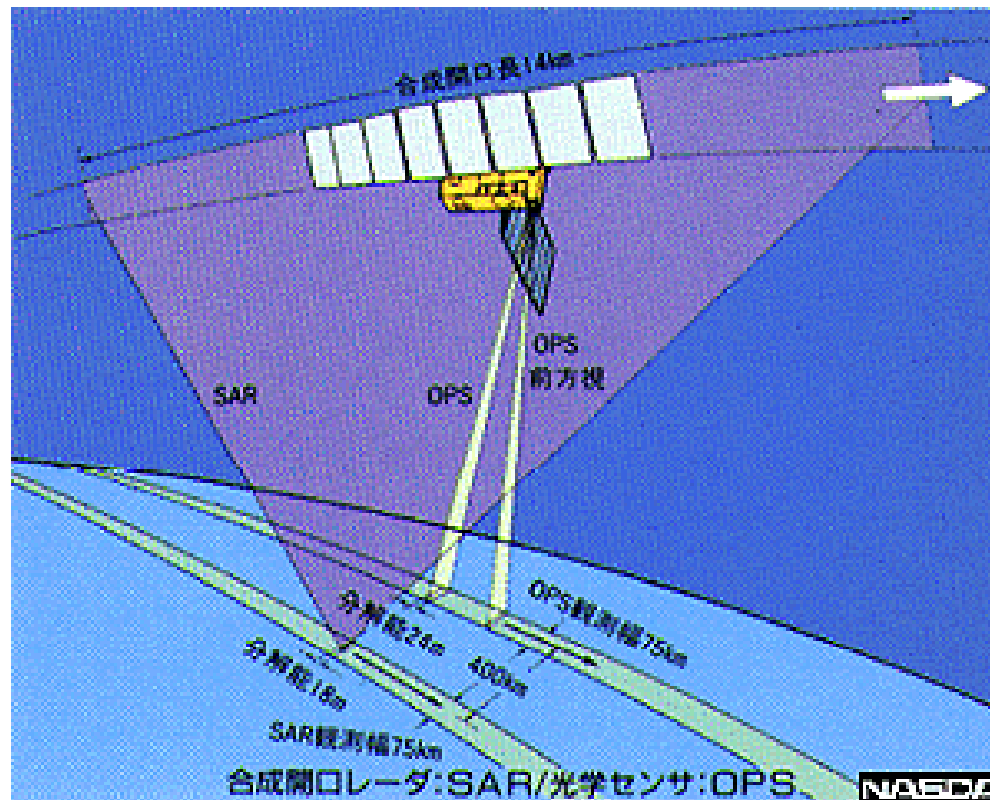

GPR profile from buried pipes

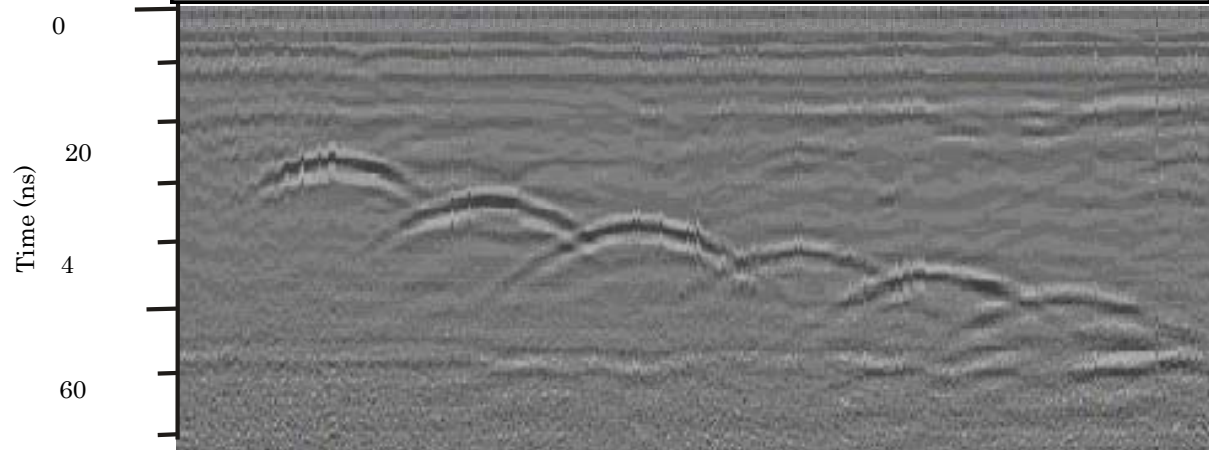
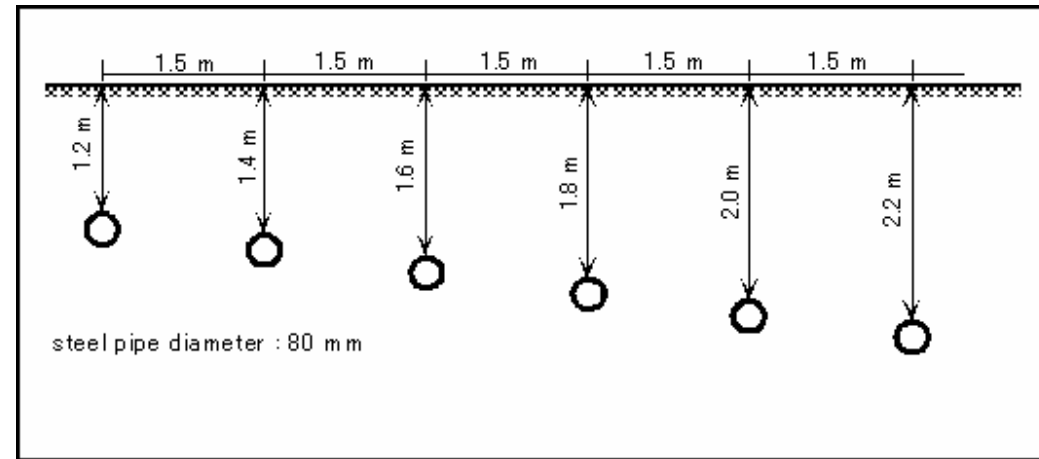

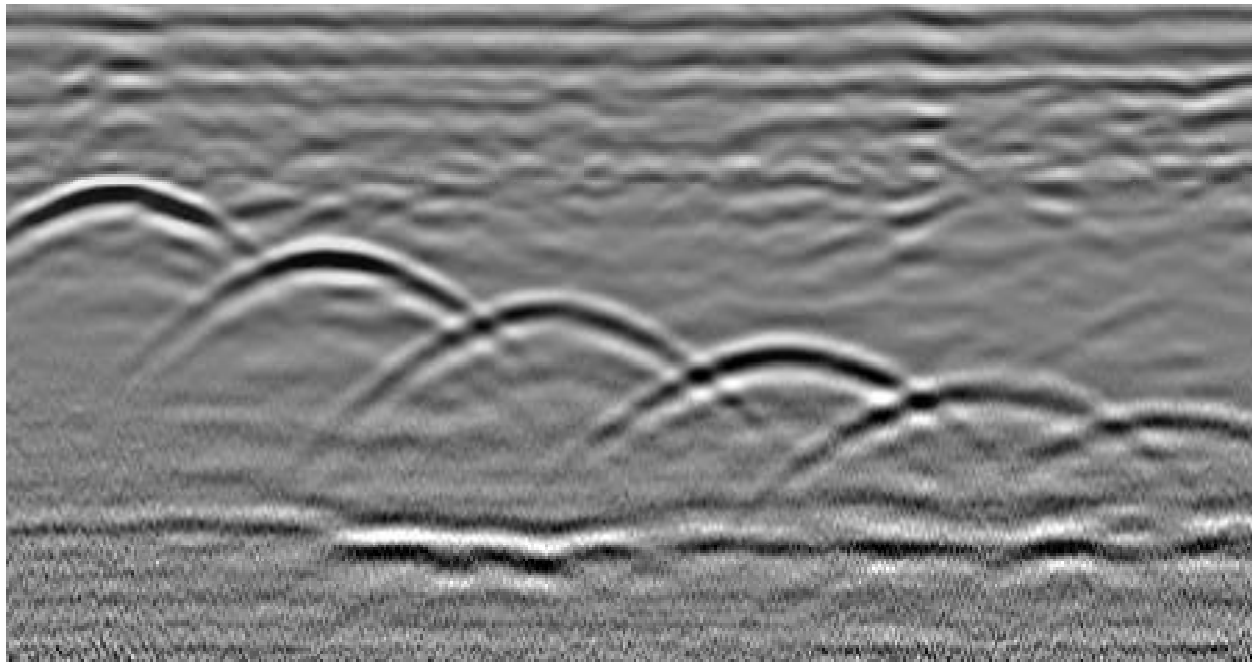

GPR profile

Raw
signal

図1 地中レーダによる埋設管検知例（大阪ガス早川秀樹氏提供）

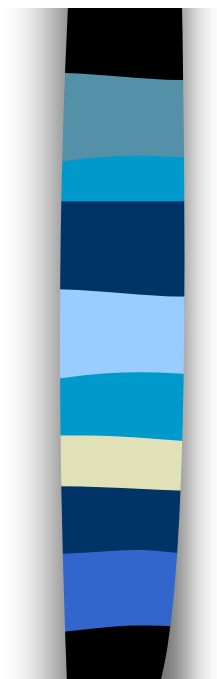

Migration



図2 f-kマイグレーション処理を行った波形

Microwave Remote sensing SAR

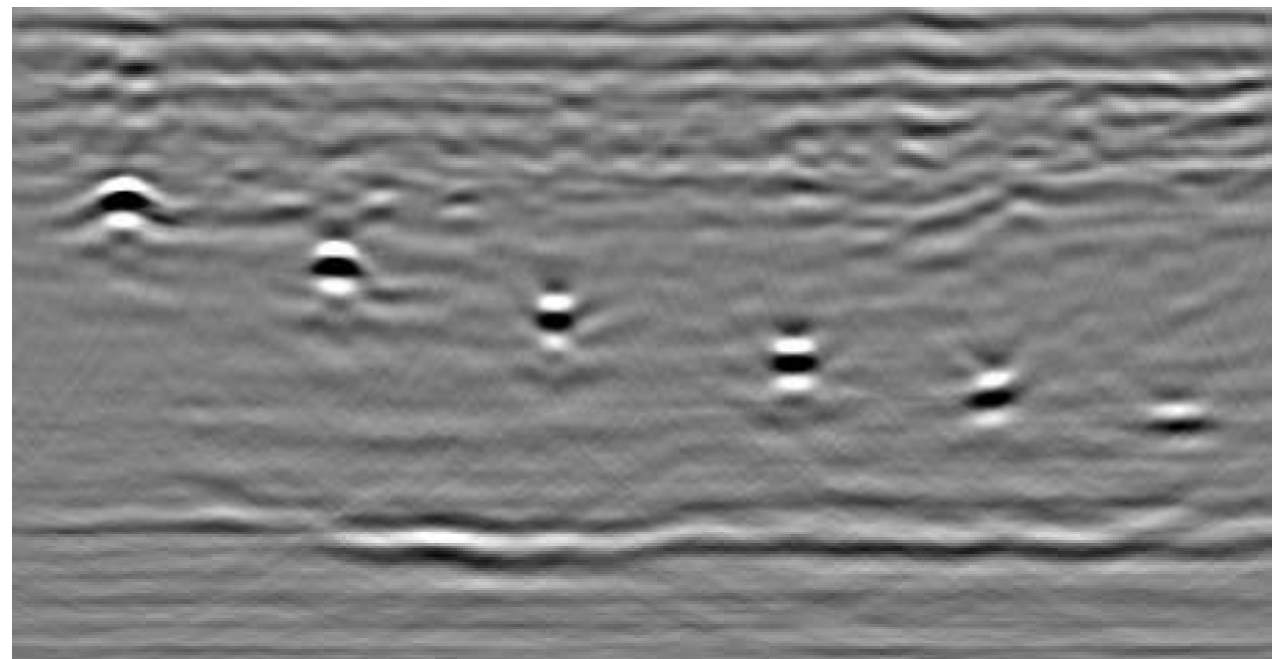
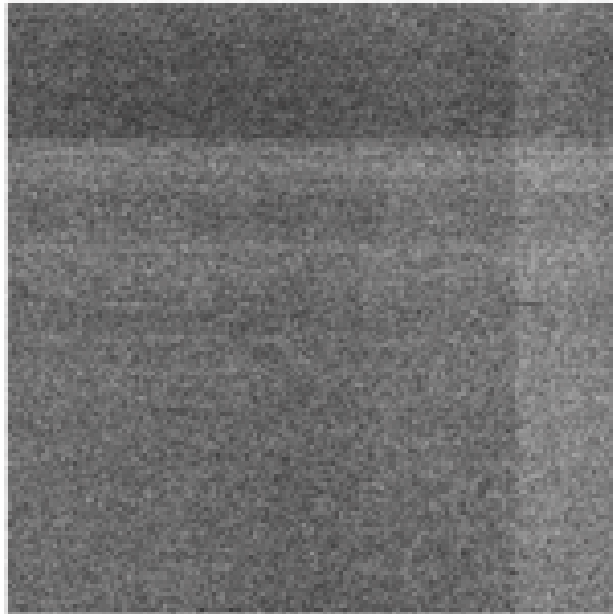

a)raw data

Raw data

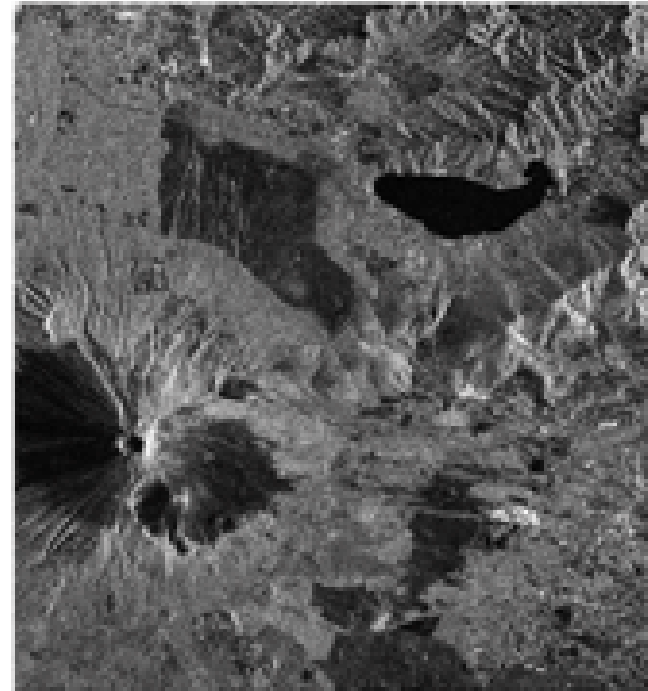

b)correlated data

SAR processed image

JERS-1, ©METI/NASDA

Optical and Microwave Sensors

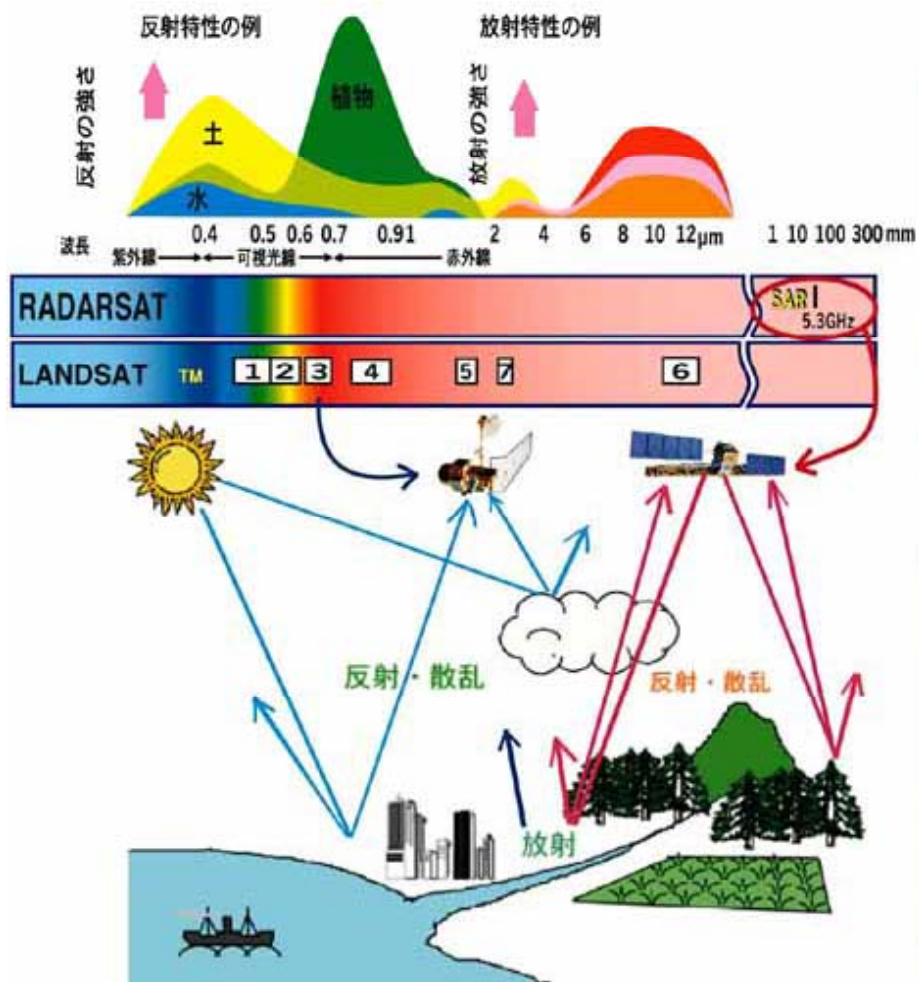

マイクロ波 (SAR) センサ



光学センサ





Why do we use microwave?

- Remote sensing (Original meaning)
- Through Fog and Cloud
- Penetration into shallow soil
- High Sensitivity to water/moisture

JERS-1 (ふよう)



JERS-1は地球の全陸域を観測し、資源探査を主目的に国土調査、農林漁業、環境保全、防災、沿岸監視等の定常観測を行う地球観測衛星。平成4年2月11日に種子島射場よりH-Iロケットで衛星高度568km、回帰日数44日の太陽同期準回帰軌道に打ち上げ。



Sensor of JERS-1

合成開口レーダ (SAR) と 光学センサ (OPS) を搭載

SAR: マイクロ波を照射し地上からの反射波をとらえて昼夜天候に左右されずに地表面の特性や起伏、傾斜などを観測する能動型センサ

OPS: 可視域から短波長赤外までを7つのバンドに分け、可視域では15.3度の前方視による立体観測が可能であり、短波長赤外では岩石や鉱物の識別に威力を発揮する

ADEOS-II (みどりII)

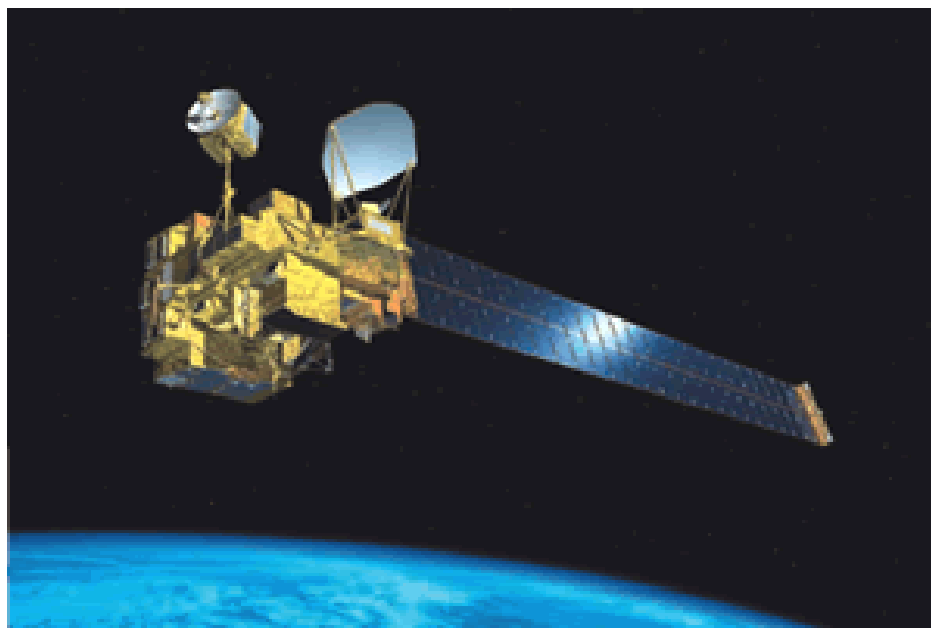

環境観測技術衛星(ADEOS-II)は、ADEOSの観測ミッションを継承し、地球温暖化等のグローバルな環境変動のメカニズムの把握や、気象や漁業等の実利用の面への貢献を図るとともに、観測技術の開発・高度化を目的とする地球観測衛星です。ADEOS-IIは、水に関する様々な量を昼夜の別なく、また雲の有無によらず高精度で観測する高性能マイクロ波放射計(AMSR)及び海域、陸域、雲等広範囲の観測対象を高精度で観測するグローバル・イメージャー(GLI)の2つのNASDAセンサに加えて、国内外の他機関から提供される3つのセンサを搭載して、水・エネルギー循環・炭素循環の解明に必要なデータを取得し、世界的な環境変動研究に貢献することが期待されています。

•2002年12月16日打ち上げ

ADEOSのセンサ

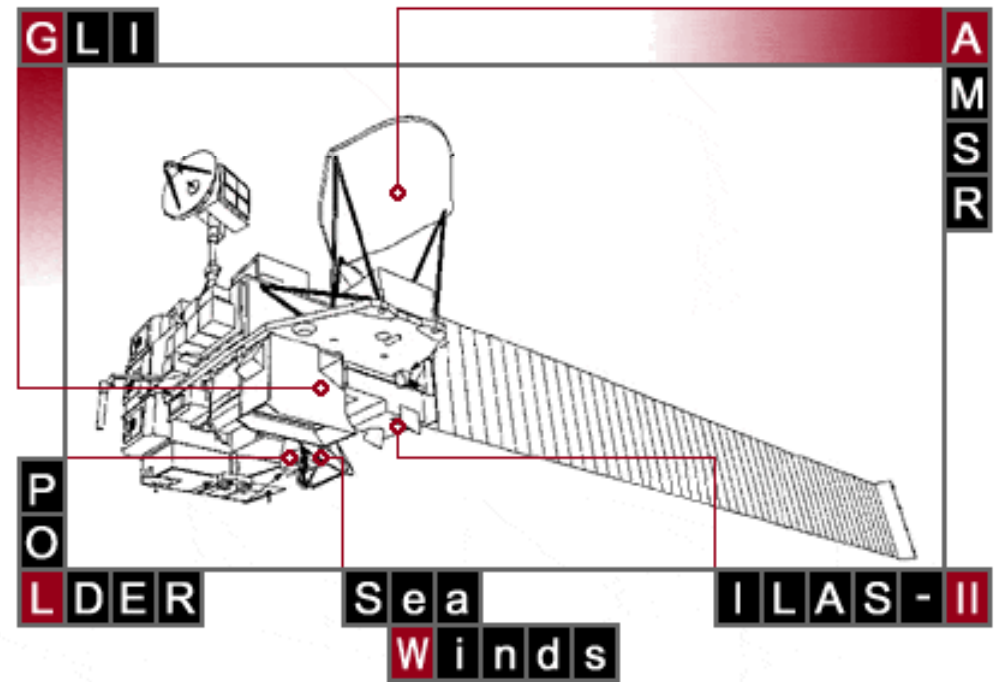

AMSR(高性能マイクロ波放射計) 地球表面および大気から放射されるマイクロ波帯の電波を測定し、主に水に関する様々な地球物理量を推定

GLI(グローバル・イメージャー) 地球表面及び雲からの太陽反射光、赤外放射光を観測し、クロロフィル濃度、溶存有機物、表面温度、植生分布、植生バイオマス、雪氷分布、雪氷アルベド、エアロゾル量、雲微物理量、など測定する光学センサ

ILAS-II(改良型大気周縁赤外分光計II型) 南北両半球の高緯度地域の成層圏のオゾン層を監視・研究するため環境庁が開発する大気センサ

SeaWinds(海上風観測装置) マイクロ波の海面による散乱測定

POLDER(地表反射光観測装置) 地球表面、エアロゾル、雲、海で反射される太陽光の偏光、方向性及び分光特性を測定。可視から近赤外までの8つのバンド(443,490,565,670,763,765,865,910nm(偏光なし)、443,670,865nm(3種の異なる偏光))

ALOS

To be launched Summer 2005

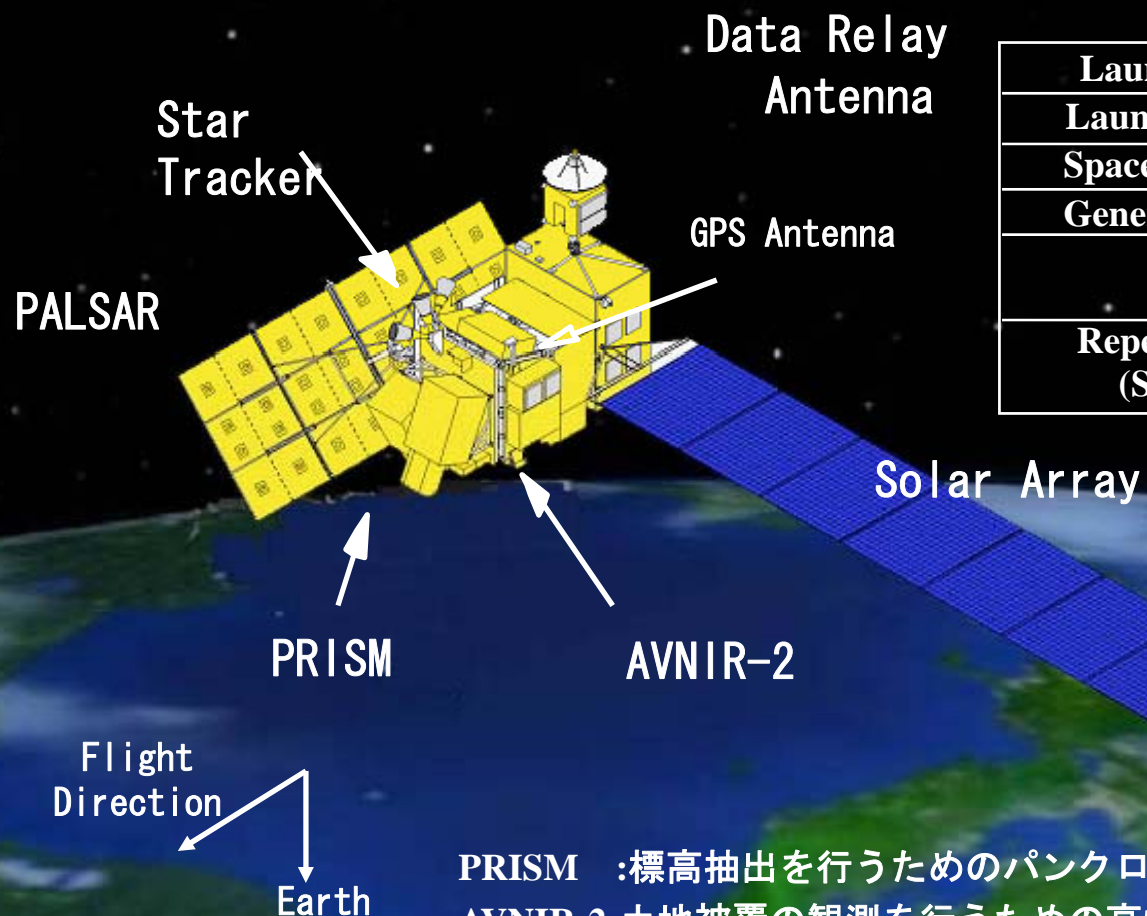

Launch Date	June 2004
Launch Vehicle	H-IIA
Spacecraft Mass	4,000kg
Generated Power	7kW
Orbit	691.65km Sun Synchronous
Repeat Cycle (Sub-Cycle)	46 days (2 days)

PRISM :標高抽出を行うためのパナロマチック立体視センサ
 AVNIR-2:土地被覆の観測を行うための高性能可視近赤外放射計2型
 PALSAR:フェーズドアレイ方式レバンド合成開口レーダ

H-IIA 8th Launch January 2006



PALSAR specifications

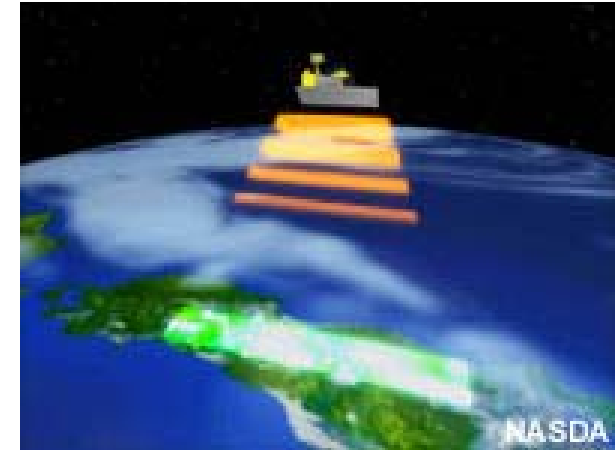

Observation mode	High resolution	Broad observation
Frequency	L-band(1.27GHz)	
Polarization	HH,VV,HH&HV,VV&VH	HH,VV
Resolution	10m	100m
Swath width	70km	250-350km
Off nadir angle	10-51 degree	
Noise-RCS	Ca. -23dB	

Biwako lake (PALSAR)



Philippines Late Island (AVNIR-2)

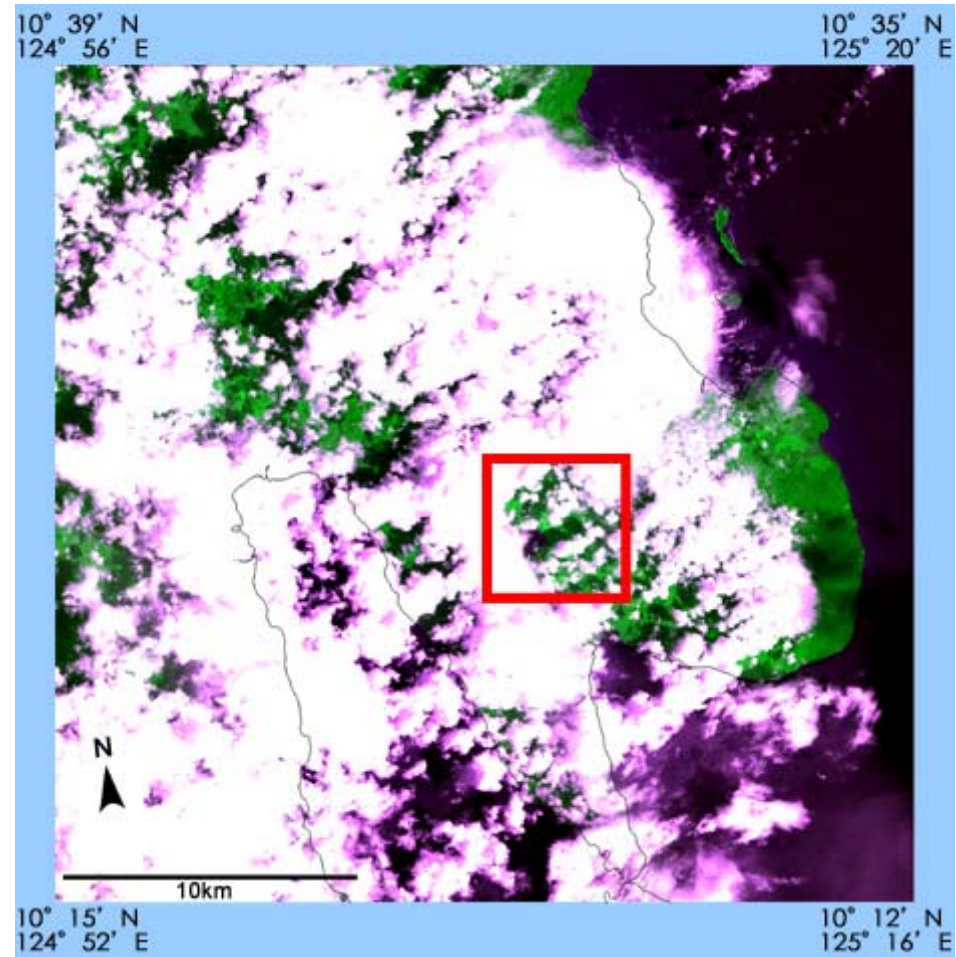

Shimizu port, Shizuoka (ALOS) (PRISM)



ALOS/PALSAR

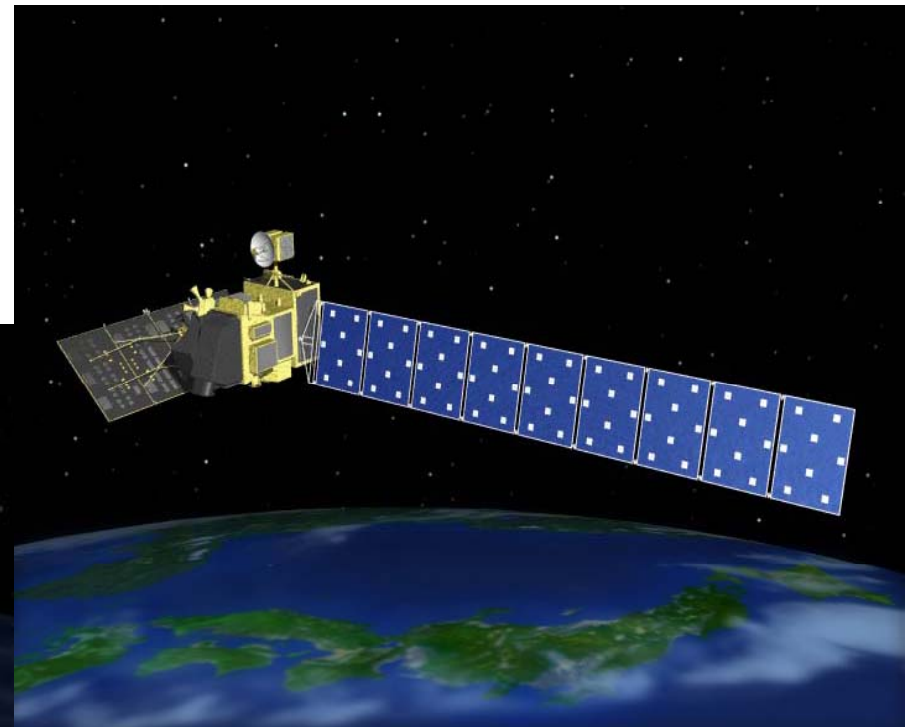
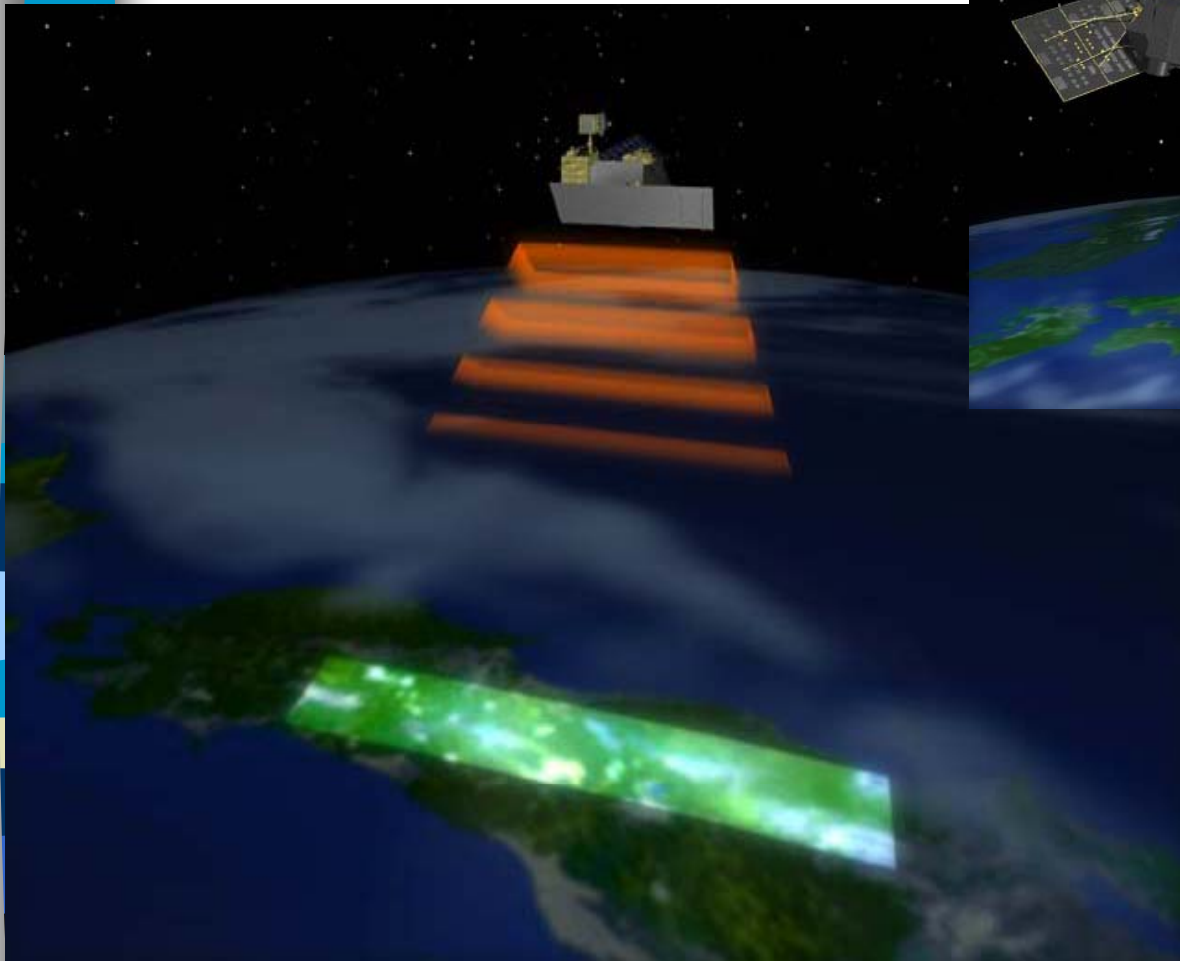

ALOS under assembly in Tsukuba Center

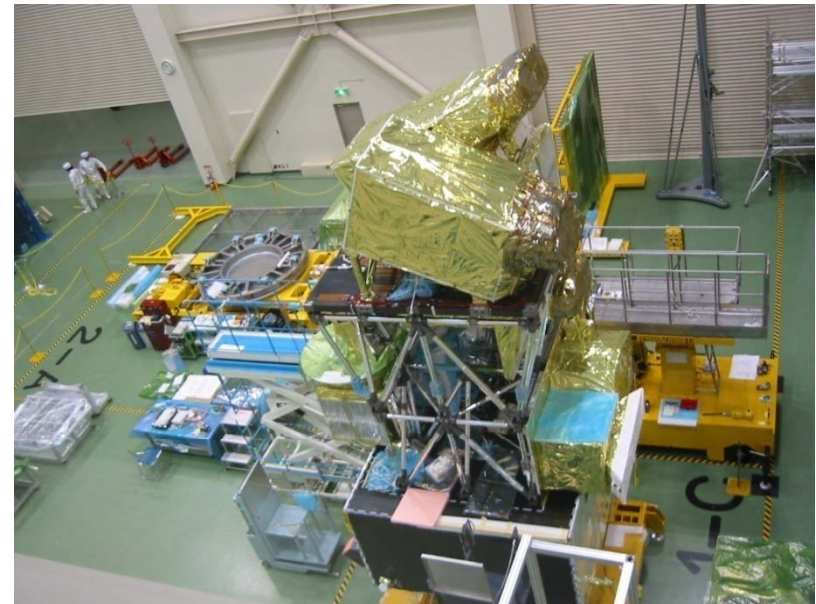

http://www.jaxa.jp/missions/projects/sat/eos/alos/index_j.html

Resolution



resolution : 8m

ADEOS/AVNIR

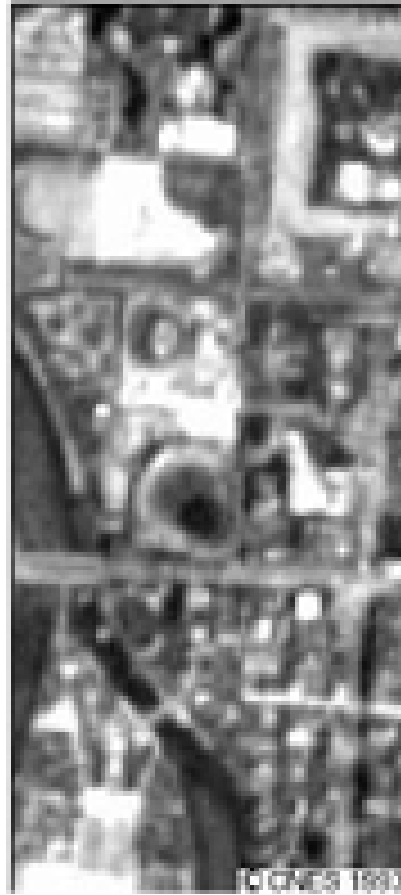

ca.10m

SPOT/HRV-P



18m × 24m

JERS1/OPS

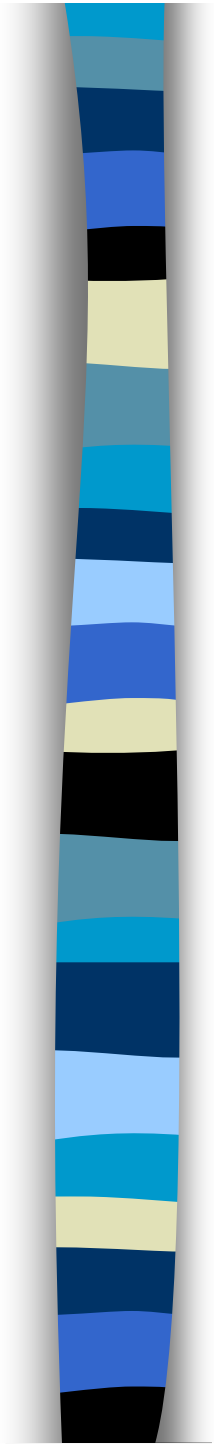

Resolution of Satellite image and Scale of map

	Satellite/ Sensor	Resolution	Equivalent Scale
	NOAA AVHRR 0.82-12.4 μ m,5bands	1000m	1:2,500,000
1	Landsat TM 0.45-2.35 μ m,7bands	30m	1:75,000
2	ERS-2 SAR 5.3GHz	30m	1:60,000
3	SPOT XS 0.5-0.59,0.61-0.68,0.79-0.89 μ m	20m	1:50,000
4	JERS-1 SAR 1.275GHz	18mx24m	1:50,000
5	SPOT PAN 0.51-0.73 μ m	10m	1:25,000
6	Quick Bird パンクロ 450-900 μ m	1m	1:1,500
	Pi-SAR 9.55GHz	1.5m	

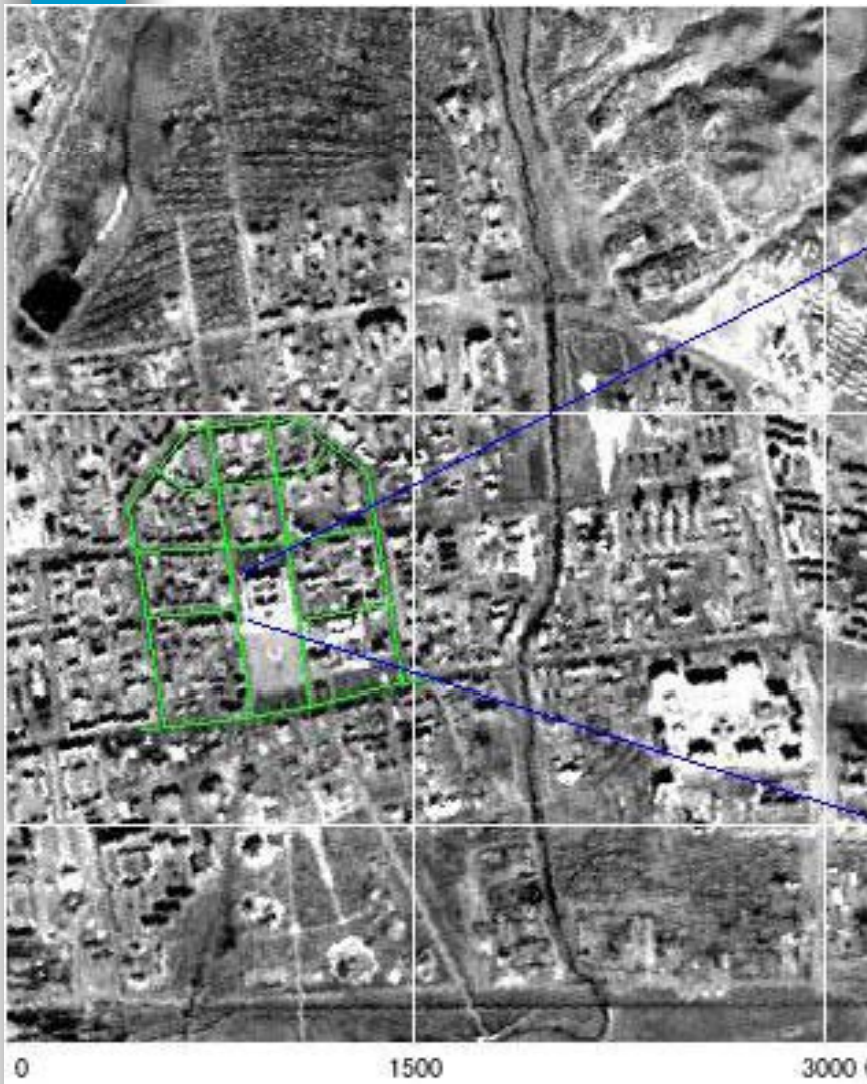

a)

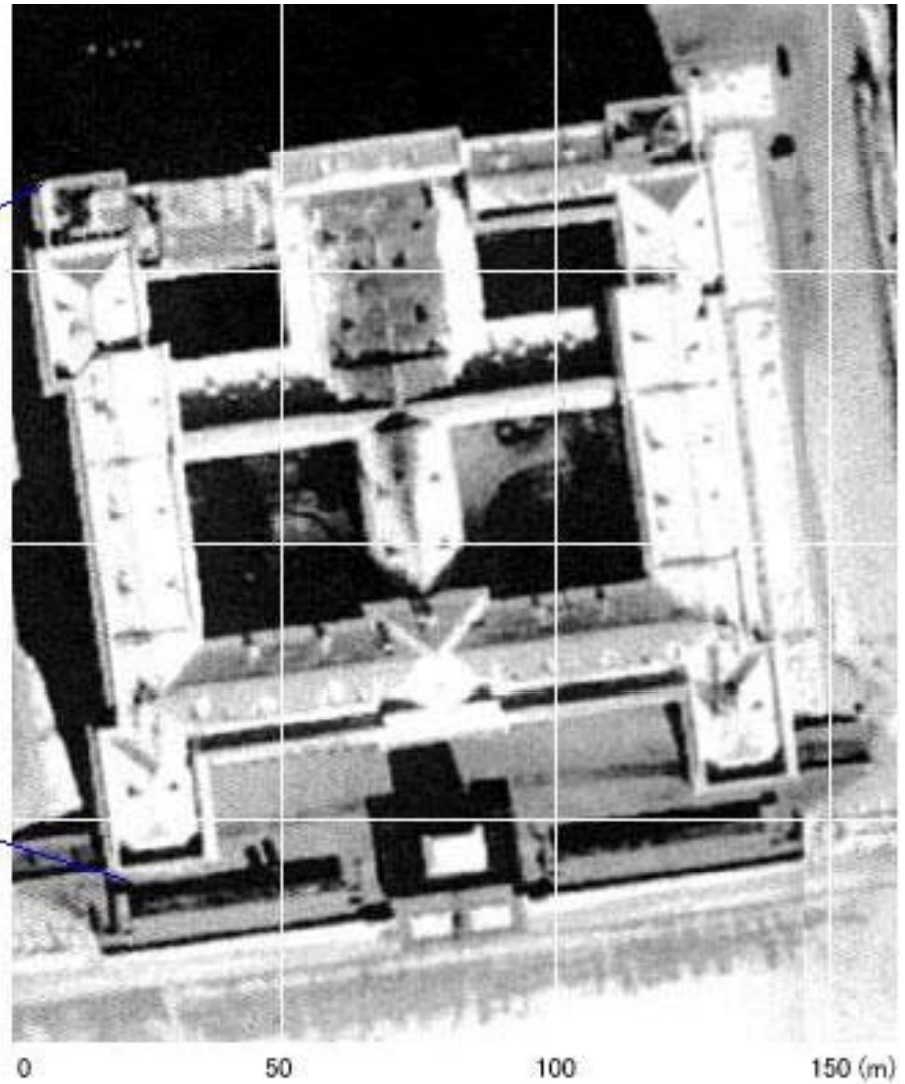

b)

**Comparison between the Captured Map Elements
on the SPOT PAN (a) and Quickbird Images (b)**

IKONOS



東京お台場付近,提供:スペースイメージング社)



Multi-channel Information

Information for analysis of
the ground surface
condition and classification

Hyper Spectrum (Multi-frequencies)

Radar Polarimetry (Polarization
information)

Pseudo-Color

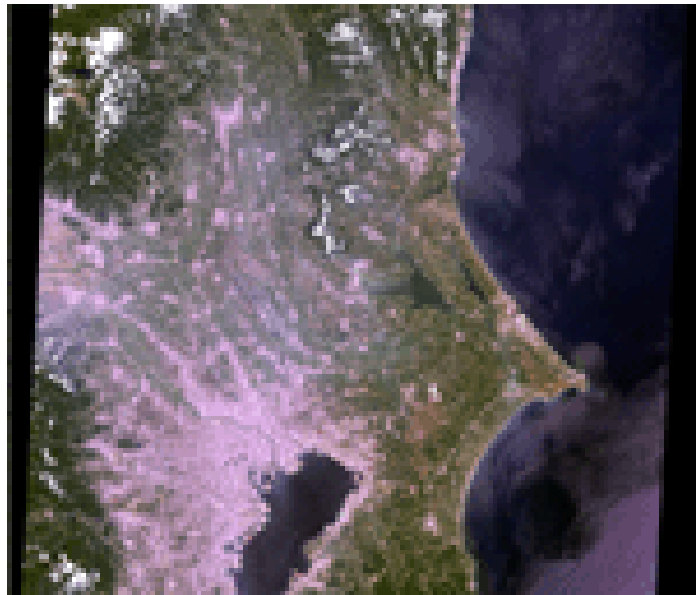

Landsat TM

Blue
band1

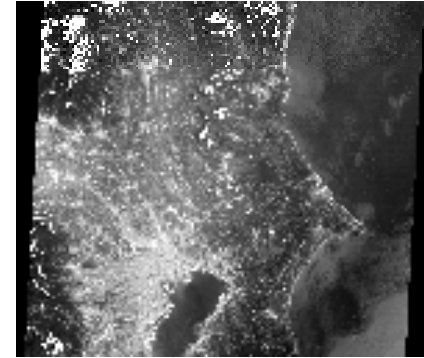

Green
band2

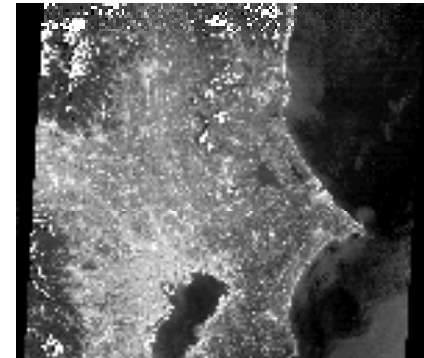

Red
band3



Pi-SAR+ALOS

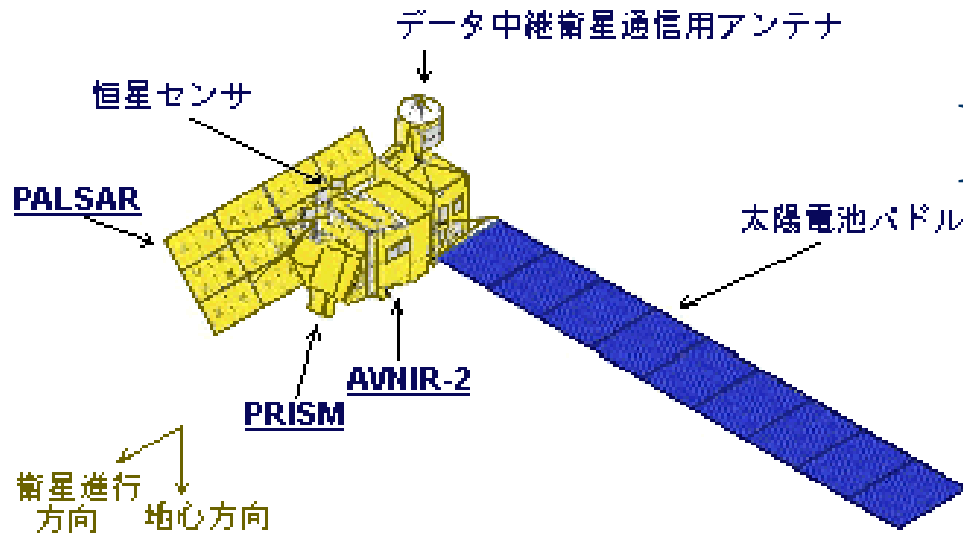

Pi-SAR

Red:HH
Green:HV
Blue:VV

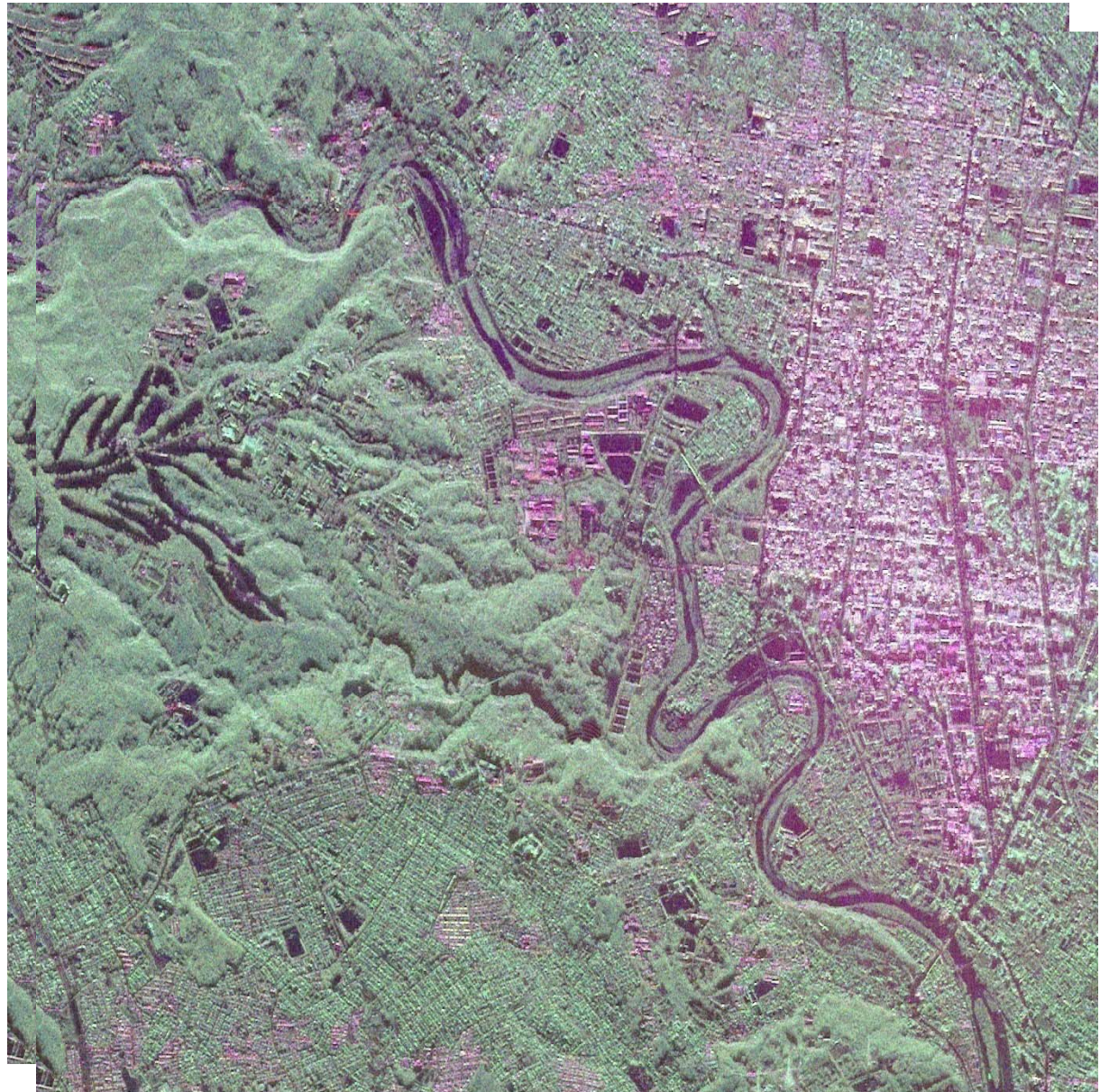

L-band, 30/08/2001 仙台市

Sendai Historical Museum

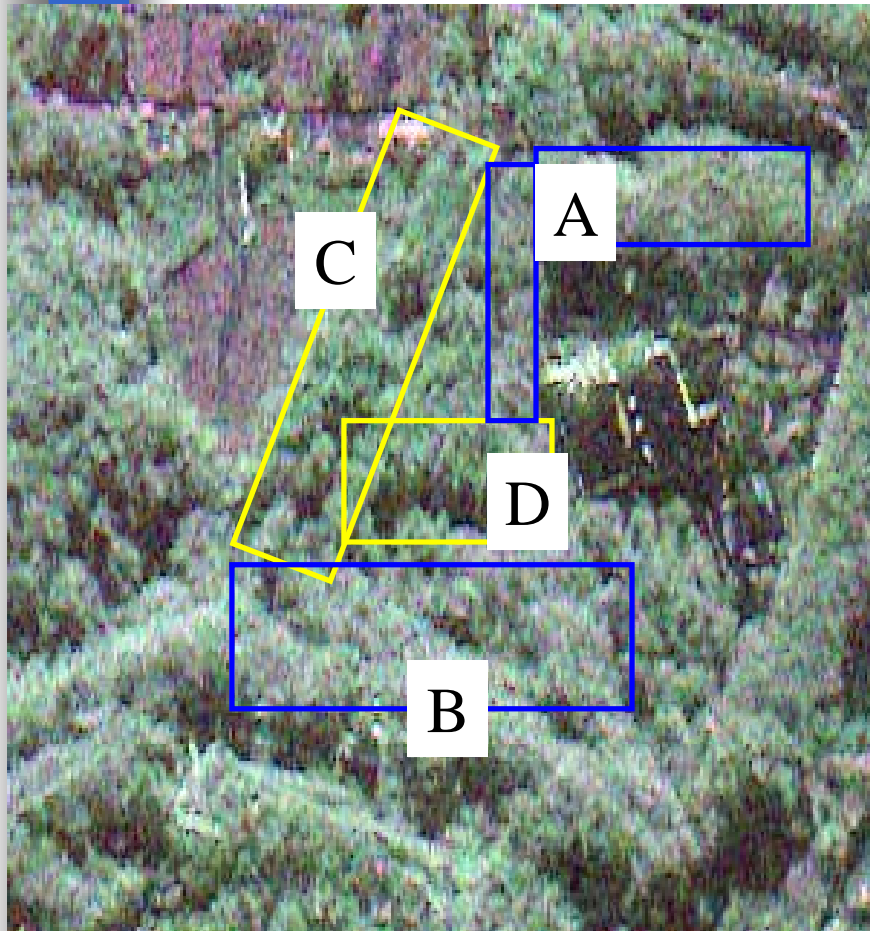

Blue site A, B: Broad leaf

Yellow site C, D: conifer

Around the museum



Site A



Site B



Site C



Site C



Site D

Pi-SAR classification of forest trees

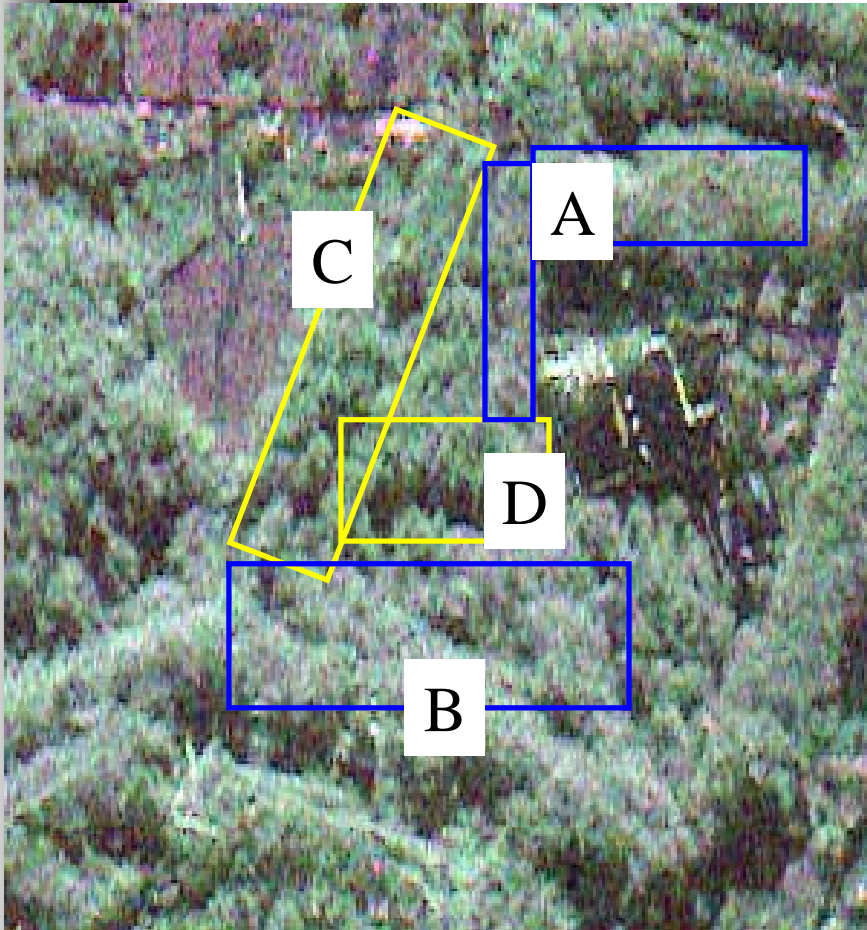

X-band, 30/08/2001 375m*400m

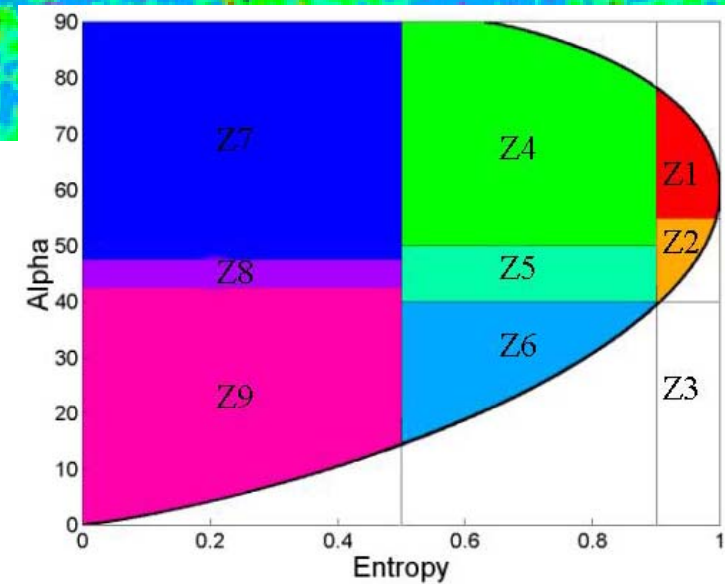
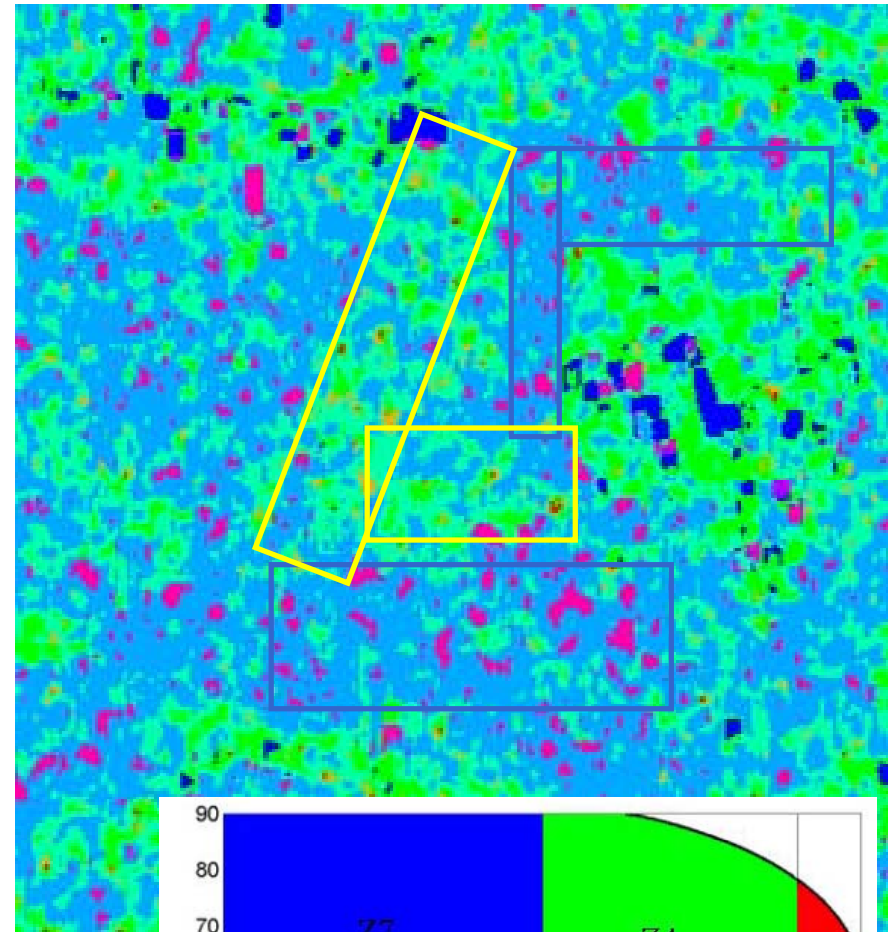

Pi-SAR
image of
Sendai city

L-band,
30/08/2001
仙台市

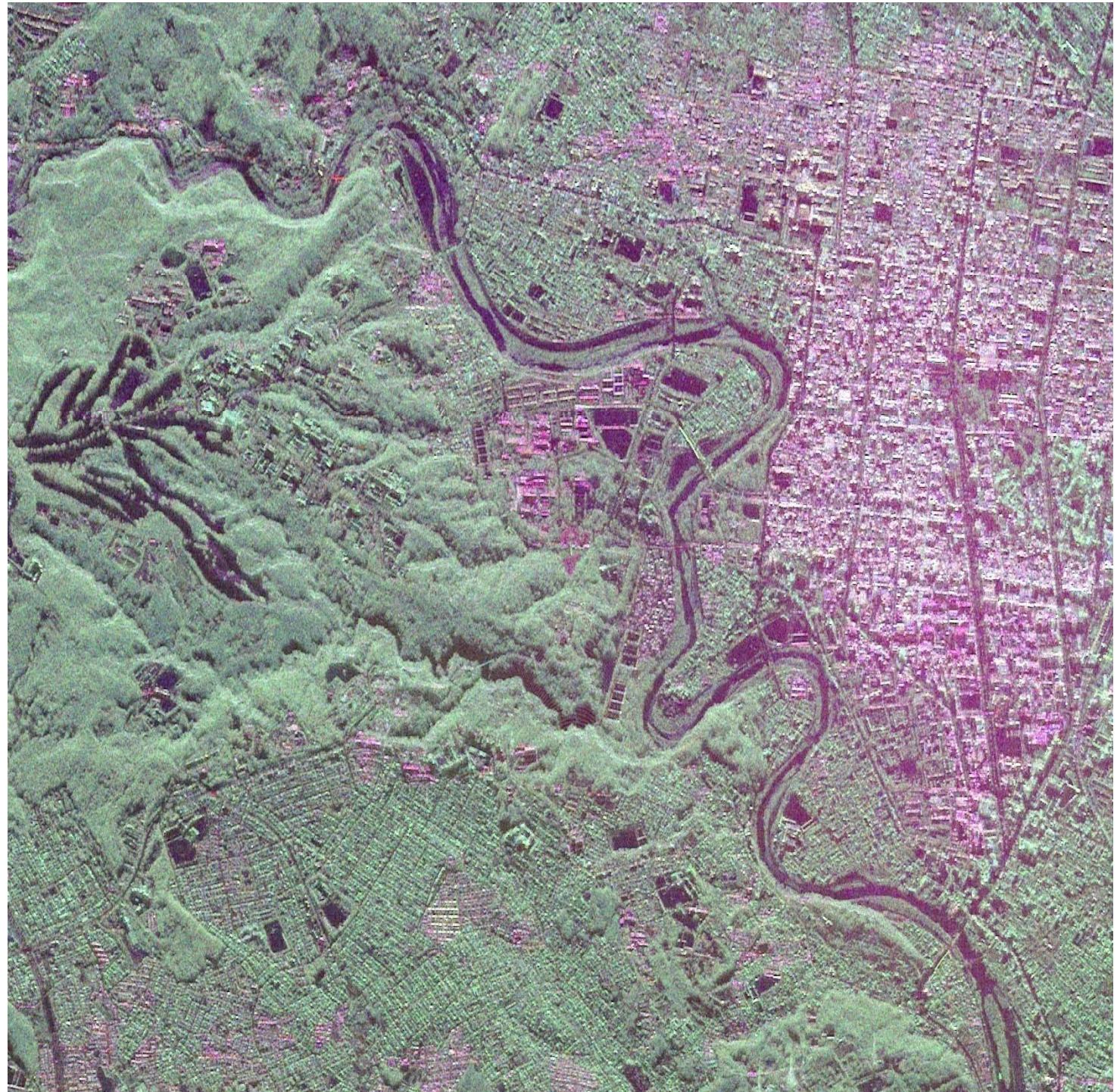

Pi-SAR Gamou- wet land image

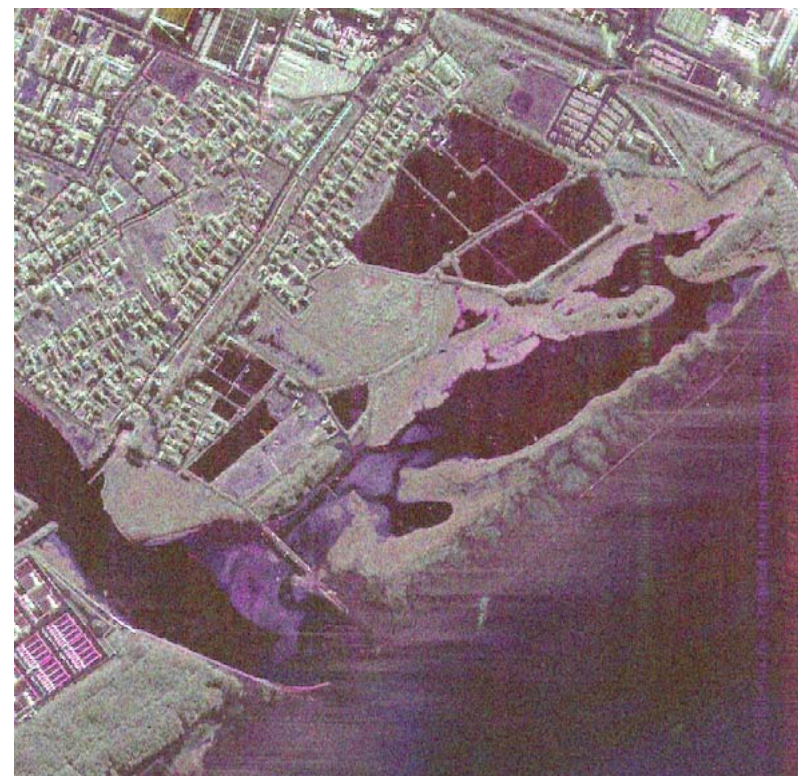

Remote sensing + GIS

Digitized Map Features overlaid on Top of the TM Bands

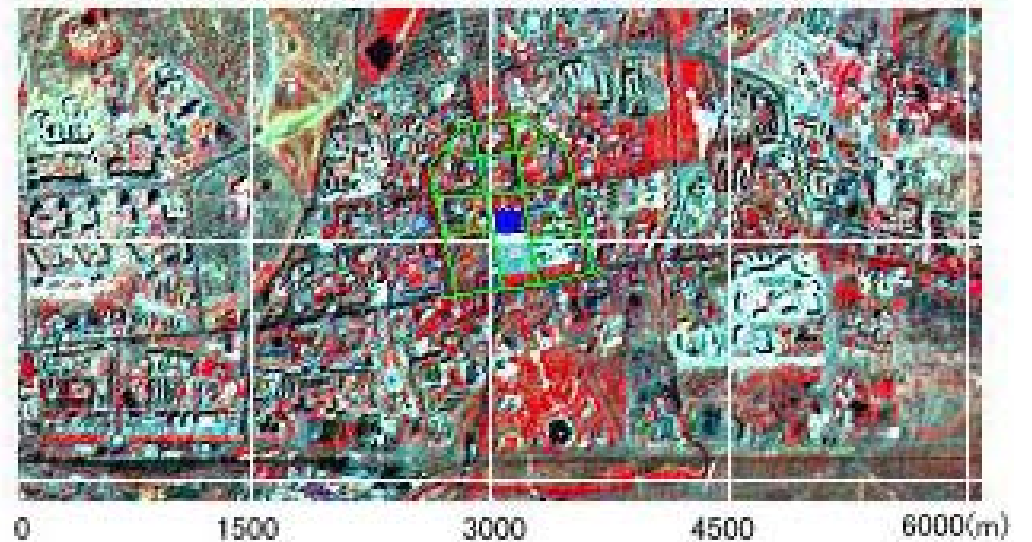
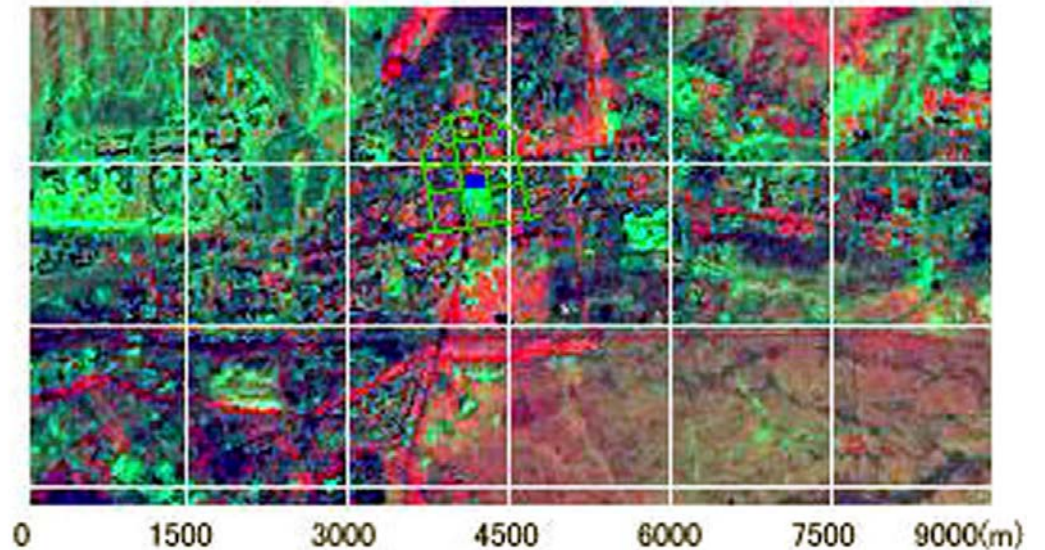

Interpreted Map Features overlaid on Top of the Enhanced SPOT XS Image

SPOT



Topographic map, Central area of Ulaanbaatar, 1984, 1:50000

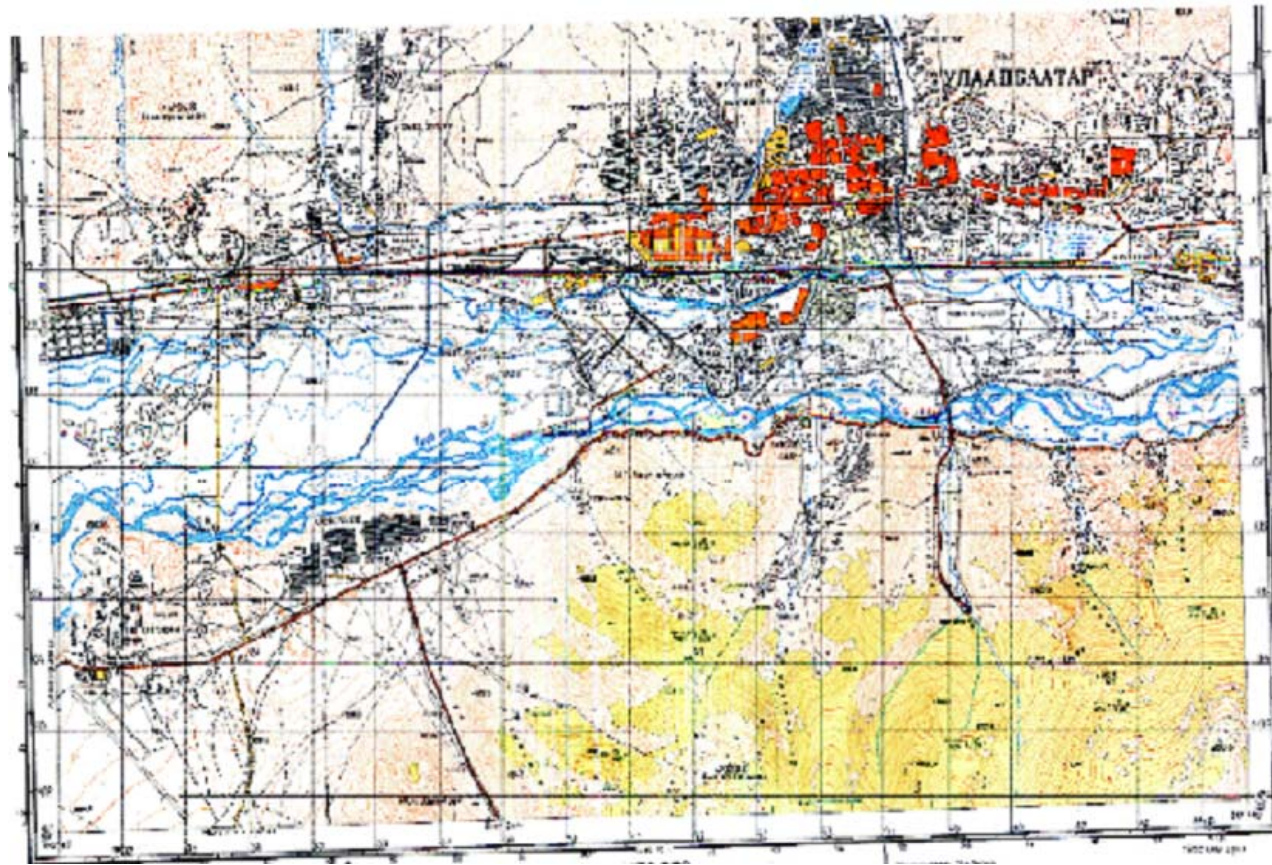

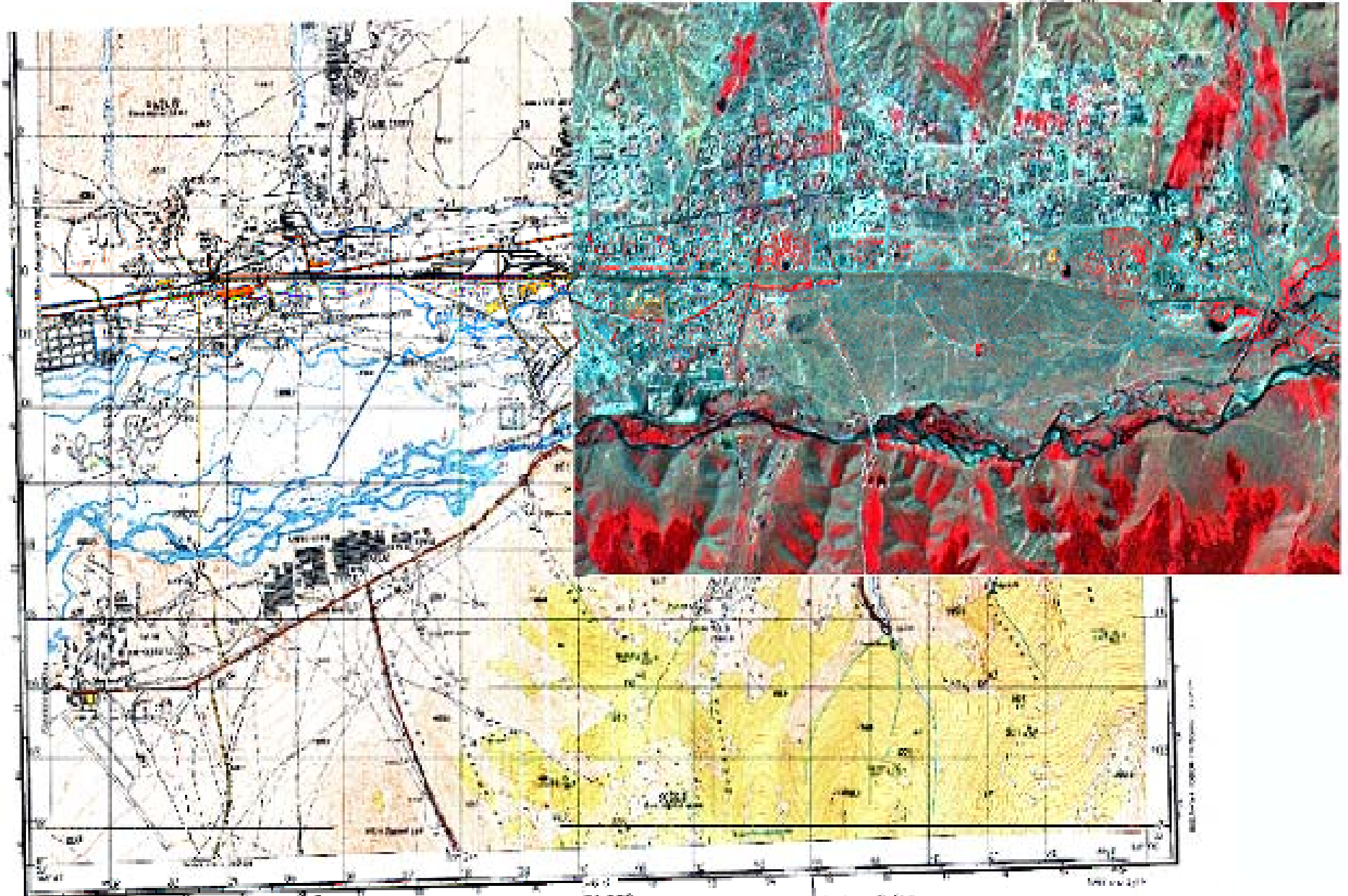

1:50,000
 Karun River
 1960
 Scale 1:50,000
 1:50,000
 Karun River
 1960
 Scale 1:50,000



Karun River
 1960
 Scale 1:50,000

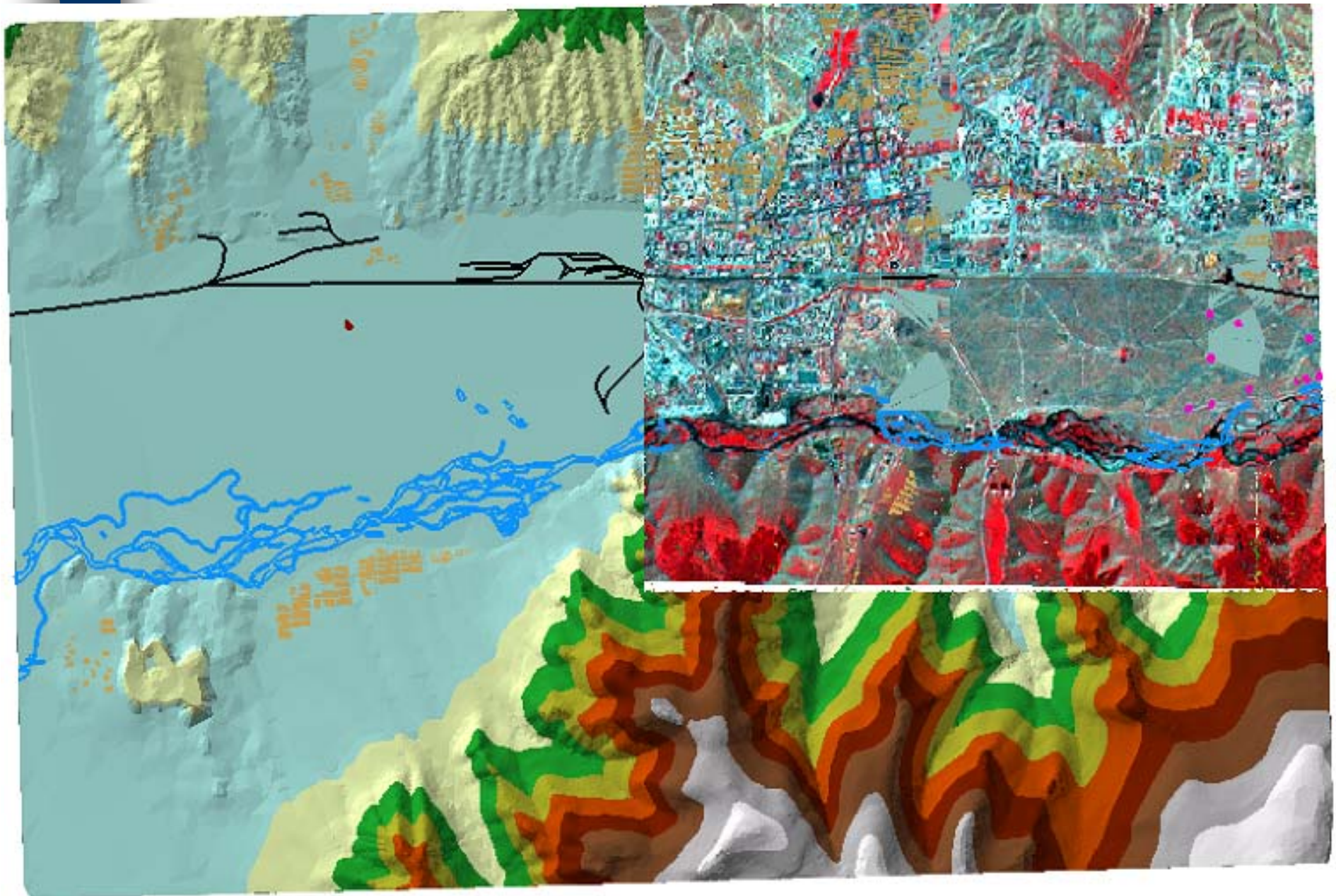

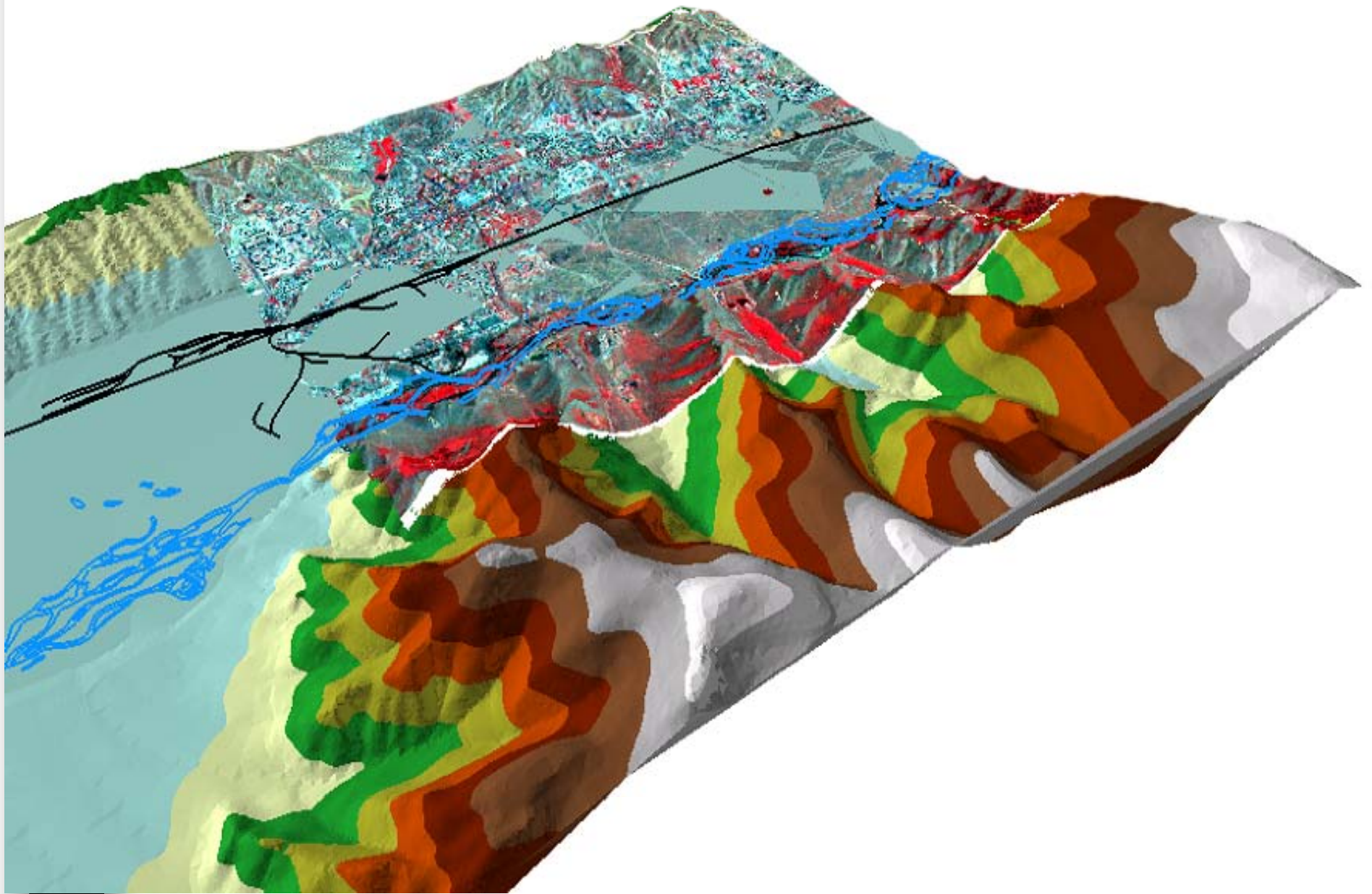

SAR Interferometry

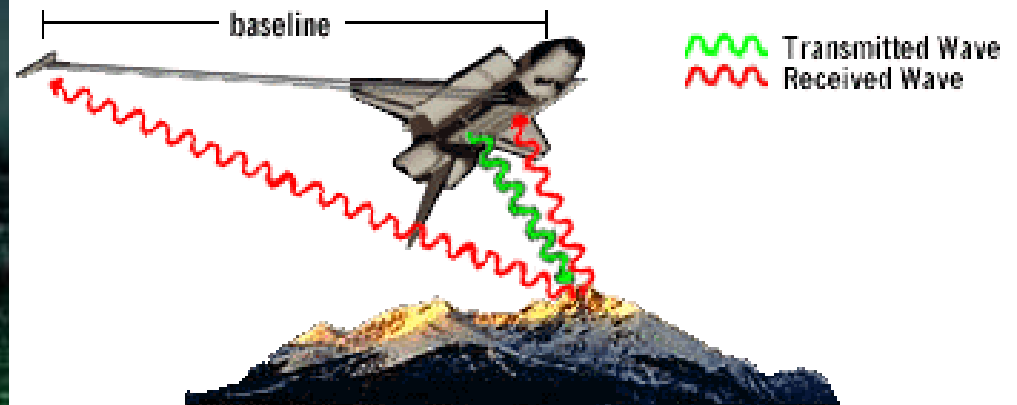

Radar signals being transmitted and received in the SRTM mission (image not to scale).



DEM (Digital Elevation Model)

**PIA02740:
3-D Perspective View, Kamchatka Peninsula, Russia**

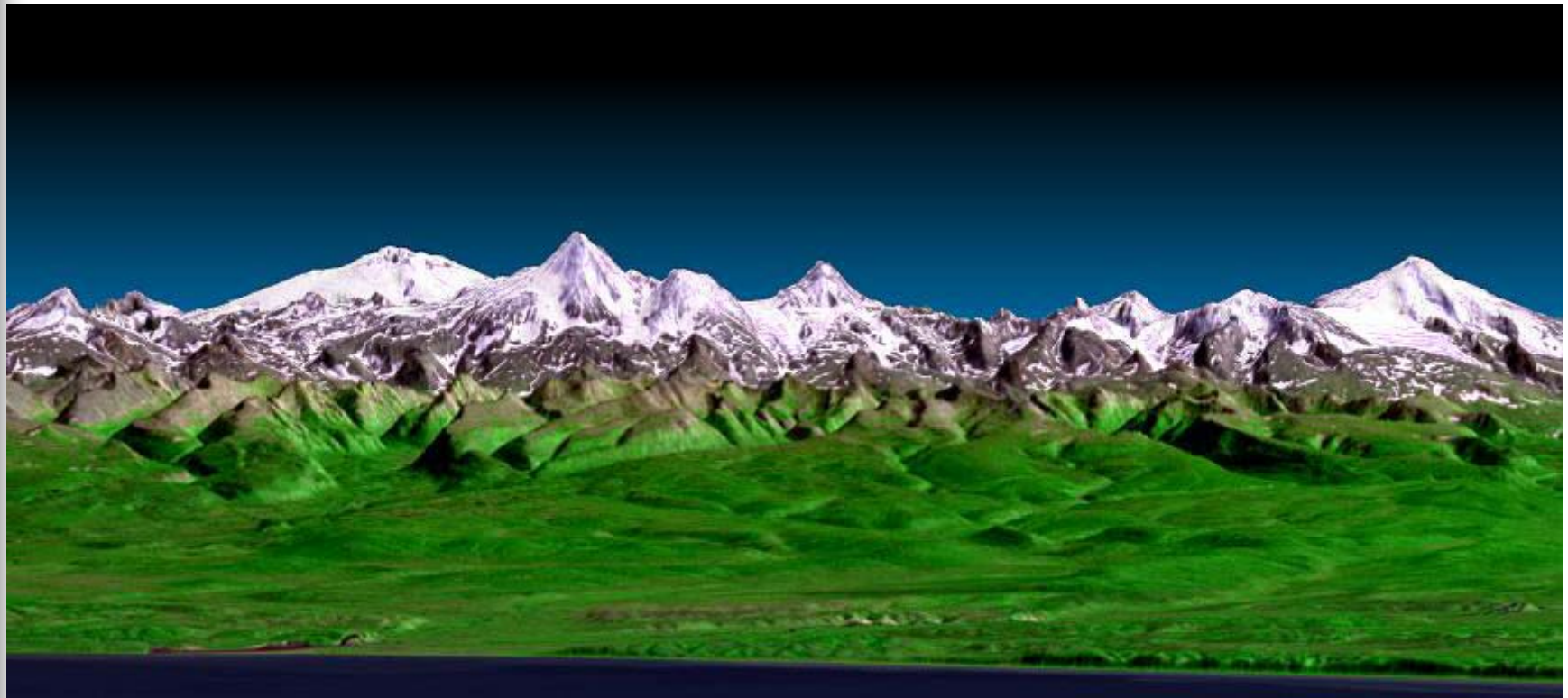

St. Helens (USA)



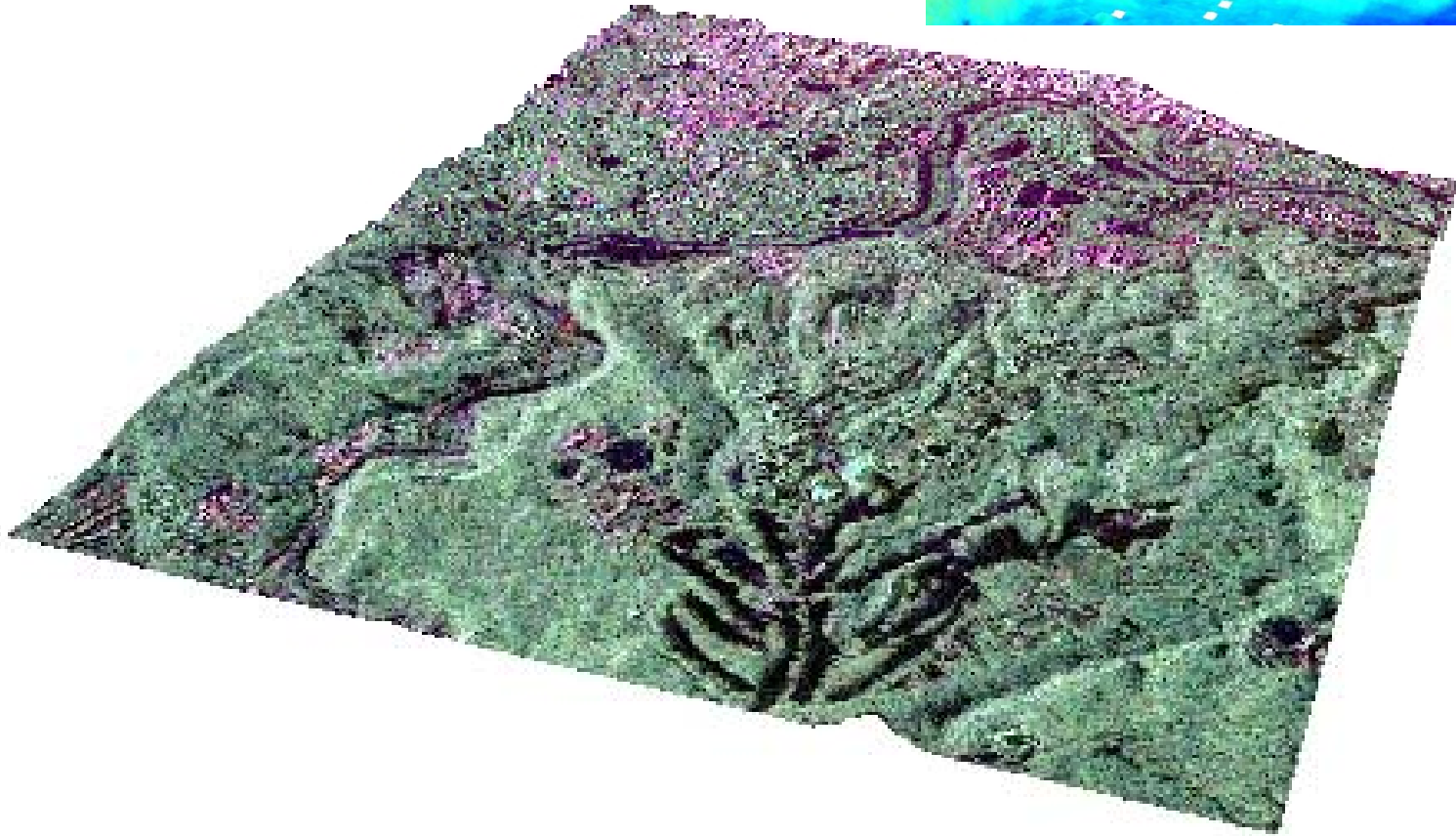
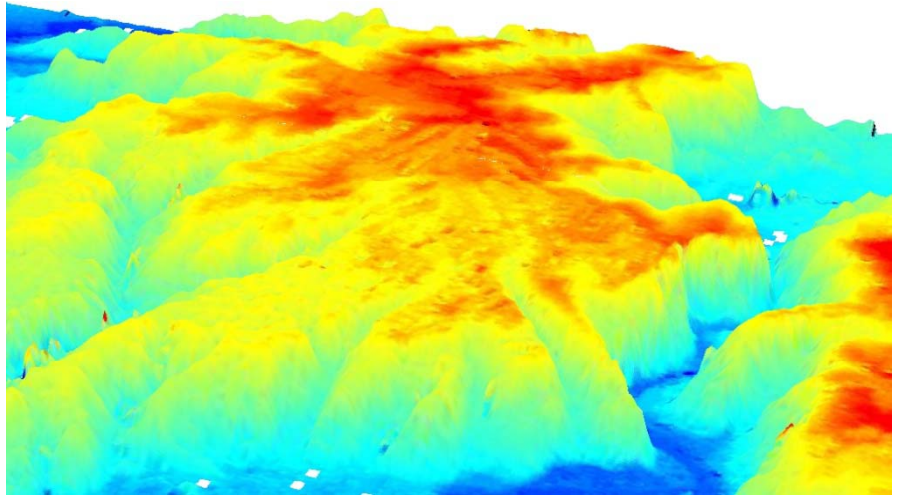



Iwate-san volcano

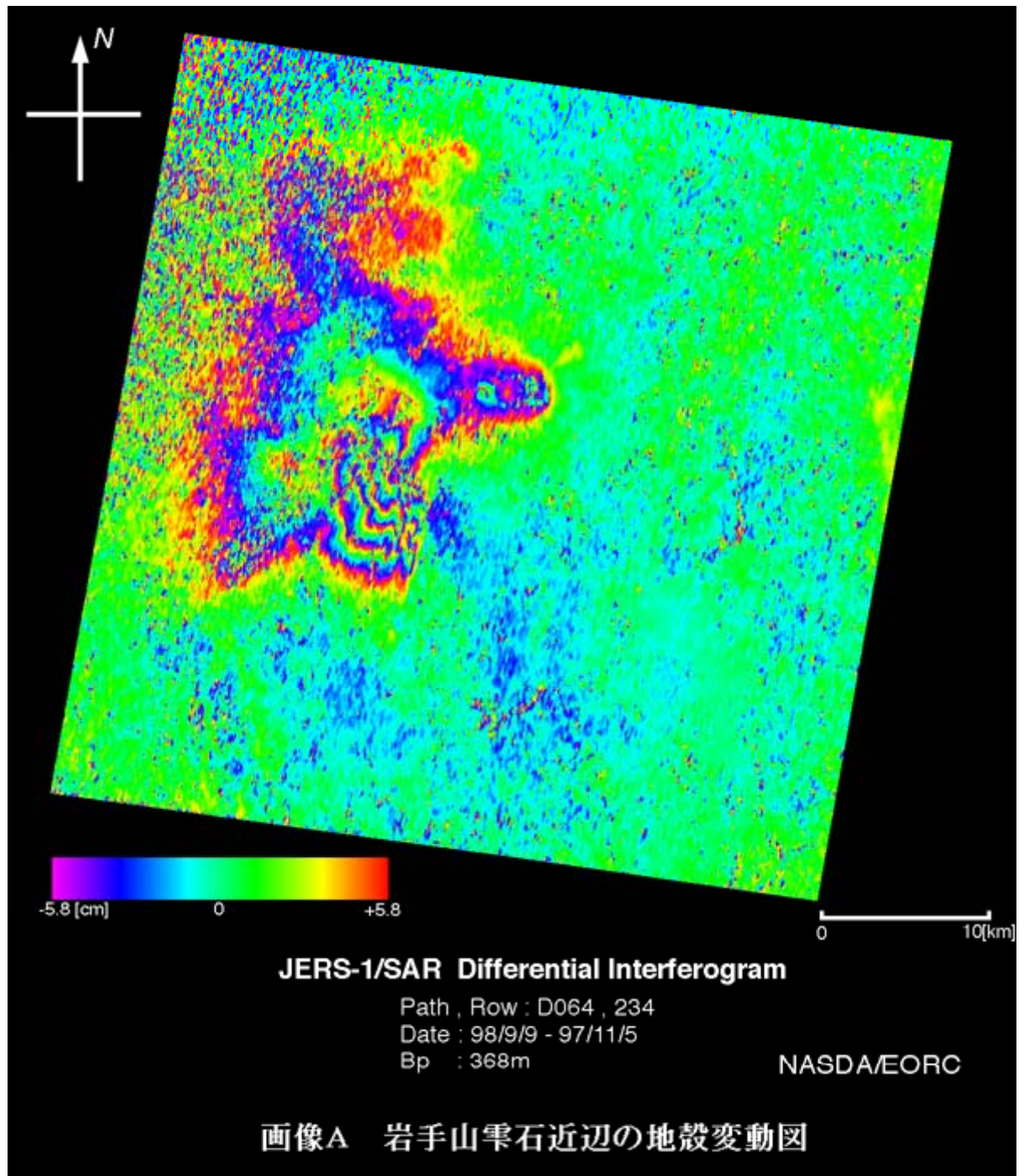



Remote sensing data source

•Research

•Commercial

NASDA	MOS, JERS, ADEOS, Landsat
RESTEC	IRS, RADARSAT, IKONOS
ERSDAC	JERS, ADEOS
Space Imaging	Landsat, IRS
USGS/EDC	Landsat, NOAA
SPOT Image	SPOT
Eurimage	Landsat, ERS